

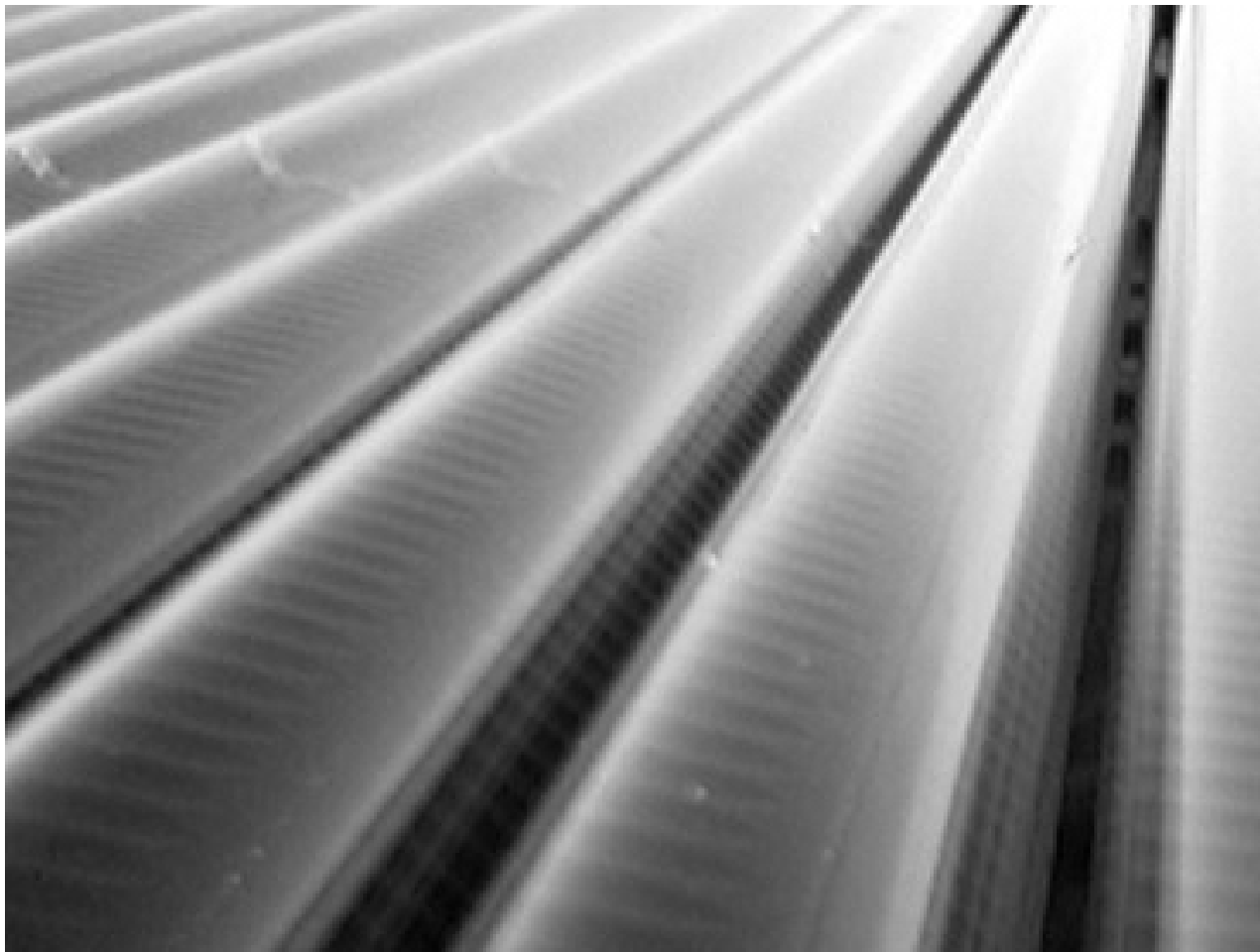

DF 100  HP 100  HP 200



Operation  
Manual



Operation  
Manual



Bedienungs-  
anleitung

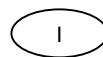

Operation  
Manual

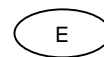

Operation  
Manual



GB

The content of this manual was correct at the time of print.. Thermomax reserves the right to change technical details without prior notice. Warranty conditions are void if the instructions of this manual are not being followed when operating the system. This manual refers to the operating of the product only. The design and sizing information can be found in the Reference Manual, the installation instructions in the Installation Manual. If any doubt arises during the installation, please contact point of purchase immediately.

F

The content of this manual was correct at the time of print.. Thermomax reserves the right to change technical details without prior notice. Warranty conditions are void if the instructions of this manual are not being followed when operating the system. This manual refers to the operating of the product only. The design and sizing information can be found in the Reference Manual, the installation instructions in the Installation Manual. If any doubt arises during the installation, please contact point of purchase immediately.

D





The content of this manual was correct at the time of print.. Thermomax reserves the right to change technical details without prior notice. Warranty conditions are void if the instructions of this manual are not being followed when operating the system. This manual refers to the operating of the product only. The design and sizing information can be found in the Reference Manual, the installation instructions in the Installation Manual. If any doubt arises during the installation, please contact point of purchase immediately.

I

The content of this manual was correct at the time of print.. Thermomax reserves the right to change technical details without prior notice. Warranty conditions are void if the instructions of this manual are not being followed when operating the system. This manual refers to the operating of the product only. The design and sizing information can be found in the Reference Manual, the installation instructions in the Installation Manual. If any doubt arises during the installation, please contact point of purchase immediately.

E

The content of this manual was correct at the time of print.. Thermomax reserves the right to change technical details without prior notice. Warranty conditions are void if the instructions of this manual are not being followed when operating the system. This manual refers to the operating of the product only. The design and sizing information can be found in the Reference Manual, the installation instructions in the Installation Manual. If any doubt arises during the installation, please contact point of purchase immediately.

				
Contents	Contents	Contents	Contents	Contents
<b>1 General Instructions</b> 5	<b>1 General Instructions</b> 6	<b>1 General Instructions</b> 7	<b>1 General Instructions</b> 8	<b>1 General Instructions</b> 9
<b>2 Commissioning of System</b> 11	<b>2 Commissioning of System</b> 14	<b>2 Commissioning of System</b> 17	<b>2 Commissioning of System</b> 20	<b>2 Commissioning of System</b> 23
2.1 Commissioning Procedure	2.1 Commissioning Procedure	2.1 Commissioning Procedure	2.1 Commissioning Procedure	2.1 Commissioning Procedure
2.2 Commissioning Record	2.2 Commissioning Record	2.2 Commissioning Record	2.2 Commissioning Record	2.2 Commissioning Record
2.3 Warranty Card	2.3 Warranty Card	2.3 Warranty Card	2.3 Warranty Card	2.3 Warranty Card
<b>3 Maintenance</b> 27	<b>3 Maintenance</b> 28	<b>3 Maintenance</b> 29	<b>3 Maintenance</b> 30	<b>3 Maintenance</b> 31
<b>4 Troubleshooting</b> 33	<b>4 Troubleshooting</b> 40	<b>4 Troubleshooting</b> 47	<b>4 Troubleshooting</b> 54	<b>4 Troubleshooting</b> 61
<b>5 Dismantling</b> 69	<b>5 Dismantling</b> 70	<b>5 Dismantling</b> 71	<b>5 Dismantling</b> 72	<b>5 Dismantling</b> 73
5.1 Procedure	5.1 Procedure	5.1 Procedure	5.1 Procedure	5.1 Procedure
5.2 Recycling Details	5.2 Recycling Details	5.2 Recycling Details	5.2 Recycling Details	5.2 Recycling Details



**1 General Instructions**



**1 General Instructions**

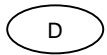

**1 General Instructions**



**1 General Instructions**



**1 General Instructions**

## 1 General Instructions

### Scope of Manual

Please note that this manual refers only to the commissioning, operation, maintenance and dismantling of the Thermomax Evacuated Tube Collectors DF 100, HP 100 and HP 200. Information relating to system design is found in the Reference Manual and about the installation in the Installation Manual (included in delivery). Thermomax reserves the right to change this document and its content without notice.

This manual is for the trained installer only. Before commencing the operation please ensure to:

- read this manual carefully
- check the installation as recommended in this manual and in accordance with local regulations
- set-up and provide required safety equipment
- have all tools available
- keep the collector loop cold to avoid artificial aging of the heat transfer fluid and unreliable pressure measurements

### Use of Manual

This manual describes the commissioning, operation, maintenance and dismantling procedure for the Thermomax DF 100, HP 100 and HP 200 collectors. Contained is also a warranty card which must be completed and returned to be able to claim warranty at any stage. This manual is to be retained at the location of the installation. The end user of the system should be instructed in the basic functions of the system and the necessary steps in the event of malfunction.

### Safety Precautions

#### General

- ! The system is to be installed as described in the Installation Manual and in accordance with the relevant local standards and regulations. Should the Installation Manual contain conflicting information to local legislation, please inform Thermomax to seek clarification.
- ! The commissioning of the system should be carried out immediately after the installation of the tubes, as these start producing energy immediately. If this is not possible, the system is to be covered.
- ! Before carrying out any electrical work ensure that mains is switched off and secured in off position while work is ongoing.
- ! Relevant personal protective equipment is to be used and worn at all stages of installation, commissioning, maintenance and dismantling of system.

## 1 General Instructions

### Scope of Manual

Please note that this manual refers only to the commissioning, operation, maintenance and dismantling of the Thermomax Evacuated Tube Collectors DF 100, HP 100 and HP 200. Information relating to system design is found in the Reference Manual and about the installation in the Installation Manual (included in delivery). Thermomax reserves the right to change this document and its content without notice.

This manual is for the trained installer only. Before commencing the operation please ensure to:

- read this manual carefully
- check the installation as recommended in this manual and in accordance with local regulations
- set-up and provide required safety equipment
- have all tools available
- keep the collector loop cold to avoid artificial aging of the heat transfer fluid and unreliable pressure measurements

### Use of Manual

This manual describes the commissioning, operation, maintenance and dismantling procedure for the Thermomax DF 100, HP 100 and HP 200 collectors. Contained is also a warranty card which must be completed and returned to be able to claim warranty at any stage. This manual is to be retained at the location of the installation. The end user of the system should be instructed in the basic functions of the system and the necessary steps in the event of malfunction.

### Safety Precautions

#### General

- ! The system is to be installed as described in the Installation Manual and in accordance with the relevant local standards and regulations. Should the Installation Manual contain conflicting information to local legislation, please inform Thermomax to seek clarification.
- ! The commissioning of the system should be carried out immediately after the installation of the tubes, as these start producing energy immediately. If this is not possible, the system is to be covered.
- ! Before carrying out any electrical work ensure that mains is switched off and secured in off position while work is ongoing.
- ! Relevant personal protective equipment is to be used and worn at all stages of installation, commissioning, maintenance and dismantling of system.

## 1 General Instructions

### Scope of Manual

Please note that this manual refers only to the commissioning, operation, maintenance and dismantling of the Thermomax Evacuated Tube Collectors DF 100, HP 100 and HP 200. Information relating to system design is found in the Reference Manual and about the installation in the Installation Manual (included in delivery). Thermomax reserves the right to change this document and its content without notice.

This manual is for the trained installer only. Before commencing the operation please ensure to:

- read this manual carefully
- check the installation as recommended in this manual and in accordance with local regulations
- set-up and provide required safety equipment
- have all tools available
- keep the collector loop cold to avoid artificial aging of the heat transfer fluid and unreliable pressure measurements

### Use of Manual

This manual describes the commissioning, operation, maintenance and dismantling procedure for the Thermomax DF 100, HP 100 and HP 200 collectors. Contained is also a warranty card which must be completed and returned to be able to claim warranty at any stage. This manual is to be retained at the location of the installation. The end user of the system should be instructed in the basic functions of the system and the necessary steps in the event of malfunction.

### Safety Precautions

#### General

- ! The system is to be installed as described in the Installation Manual and in accordance with the relevant local standards and regulations. Should the Installation Manual contain conflicting information to local legislation, please inform Thermomax to seek clarification.
- ! The commissioning of the system should be carried out immediately after the installation of the tubes, as these start producing energy immediately. If this is not possible, the system is to be covered.
- ! Before carrying out any electrical work ensure that mains is switched off and secured in off position while work is ongoing.
- ! Relevant personal protective equipment is to be used and worn at all stages of installation, commissioning, maintenance and dismantling of system.

## 1 General Instructions

### Scope of Manual

Please note that this manual refers only to the commissioning, operation, maintenance and dismantling of the Thermomax Evacuated Tube Collectors DF 100, HP 100 and HP 200. Information relating to system design is found in the Reference Manual and about the installation in the Installation Manual (included in delivery). Thermomax reserves the right to change this document and its content without notice.

This manual is for the trained installer only. Before commencing the operation please ensure to:

- read this manual carefully
- check the installation as recommended in this manual and in accordance with local regulations
- set-up and provide required safety equipment
- have all tools available
- keep the collector loop cold to avoid artificial aging of the heat transfer fluid and unreliable pressure measurements

### Use of Manual

This manual describes the commissioning, operation, maintenance and dismantling procedure for the Thermomax DF 100, HP 100 and HP 200 collectors. Contained is also a warranty card which must be completed and returned to be able to claim warranty at any stage. This manual is to be retained at the location of the installation. The end user of the system should be instructed in the basic functions of the system and the necessary steps in the event of malfunction.

### Safety Precautions

#### General

- ! The system is to be installed as described in the Installation Manual and in accordance with the relevant local standards and regulations. Should the Installation Manual contain conflicting information to local legislation, please inform Thermomax to seek clarification.
- ! The commissioning of the system should be carried out immediately after the installation of the tubes, as these start producing energy immediately. If this is not possible, the system is to be covered.
- ! Before carrying out any electrical work ensure that mains is switched off and secured in off position while work is ongoing.
- ! Relevant personal protective equipment is to be used and worn at all stages of installation, commissioning, maintenance and dismantling of system.

## 1 General Instructions

### Scope of Manual

Please note that this manual refers only to the commissioning, operation, maintenance and dismantling of the Thermomax Evacuated Tube Collectors DF 100, HP 100 and HP 200. Information relating to system design is found in the Reference Manual and about the installation in the Installation Manual (included in delivery). Thermomax reserves the right to change this document and its content without notice.

This manual is for the trained installer only. Before commencing the operation please ensure to:

- read this manual carefully
- check the installation as recommended in this manual and in accordance with local regulations
- set-up and provide required safety equipment
- have all tools available
- keep the collector loop cold to avoid artificial aging of the heat transfer fluid and unreliable pressure measurements

### Use of Manual

This manual describes the commissioning, operation, maintenance and dismantling procedure for the Thermomax DF 100, HP 100 and HP 200 collectors. Contained is also a warranty card which must be completed and returned to be able to claim warranty at any stage. This manual is to be retained at the location of the installation. The end user of the system should be instructed in the basic functions of the system and the necessary steps in the event of malfunction.

### Safety Precautions

#### General

- ! The system is to be installed as described in the Installation Manual and in accordance with the relevant local standards and regulations. Should the Installation Manual contain conflicting information to local legislation, please inform Thermomax to seek clarification.
- ! The commissioning of the system should be carried out immediately after the installation of the tubes, as these start producing energy immediately. If this is not possible, the system is to be covered.
- ! Before carrying out any electrical work ensure that mains is switched off and secured in off position while work is ongoing.
- ! Relevant personal protective equipment is to be used and worn at all stages of installation, commissioning, maintenance and dismantling of system.

GB

## 2 Commissioning of System

- 2.1 Commissioning Procedure
- 2.2 Commissioning Record
- 2.3 Warranty Card

F

## 2 Commissioning of System

- 2.1 Commissioning Procedure
- 2.2 Commissioning Record
- 2.3 Warranty Card

D

## 2 Commissioning of System

- 2.1 Commissioning Procedure
- 2.2 Commissioning Record
- 2.3 Warranty Card

I

## 2 Commissioning of System

- 2.1 Commissioning Procedure
- 2.2 Commissioning Record
- 2.3 Warranty Card

E

## 2 Commissioning of System

- 2.1 Commissioning Procedure
- 2.2 Commissioning Record
- 2.3 Warranty Card

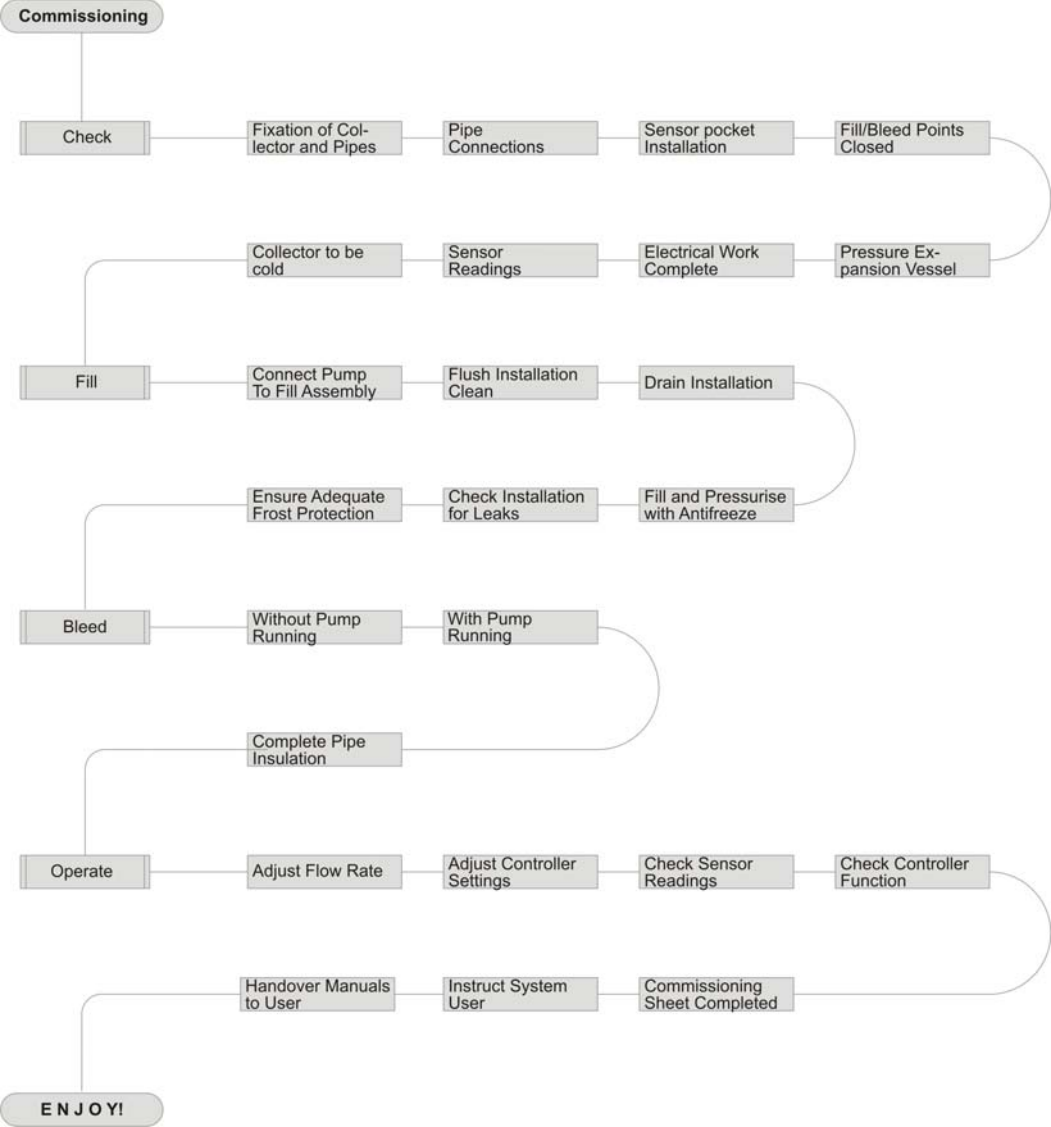

**Commissioning Record** Date \_\_\_ / \_\_\_ / \_\_\_

**Collector**

Type	Manifold	Tube
<input type="checkbox"/> DF 100	No. of 2m <sup>2</sup> _____	No. in parallel _____
<input type="checkbox"/> HP 100	3m <sup>2</sup> _____	No. in series _____
<input type="checkbox"/> HP 200	Serial No. 2m <sup>2</sup> _____	Serial No. _____
	3m <sup>2</sup> _____	_____

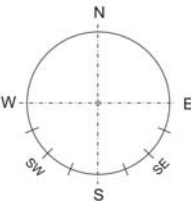
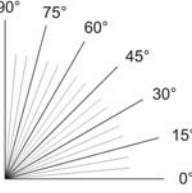
<p><b>Location</b></p> <p>Azimuth</p> 	<p>Slope</p> 	<p><b>Application</b></p> <p><input type="checkbox"/> Domestic Hot Water</p> <p><input type="checkbox"/> Heating Support</p> <p><input type="checkbox"/> Pool Heating</p> <p><input type="checkbox"/> Commercial/Industrial Application _____</p> <p><input type="checkbox"/> Thermal Refrigeration _____</p>
---	--	---

**System**

Storage Tank Overall Capacity _____ l	Expansion Vessel Capacity _____ l	Frost Protection Type _____
Solar Capacity _____ l	Pre-Pressure _____ bar	Temperature _____ °C
	Cold Fill Pressure _____ bar	Safety Valve Opening Pressure _____ bar
Control Manufacturer _____	Settings ΔT _____ K	
Type _____	Tank_Max _____ °C	
Flow Rate <input type="checkbox"/> Fixed _____ l / min	Others _____	
<input type="checkbox"/> Variable	_____	
Vacuum Tube Function <input type="checkbox"/> Yes	Copy of Controller Manual Left with Customer <input type="checkbox"/> Yes	
<input type="checkbox"/> No	<input type="checkbox"/> No	

**Warranty Card** Date \_\_\_/\_\_\_/\_\_\_

**Collector**

Type	Manifold		Tube
<input type="checkbox"/> DF 100	No. of	2m <sup>2</sup> _____	No. in parallel _____
<input type="checkbox"/> HP 100		3m <sup>2</sup> _____	No. in series _____
<input type="checkbox"/> HP 200	Serial No.	2m <sup>2</sup> _____	Serial No. _____
		3m <sup>2</sup> _____	_____

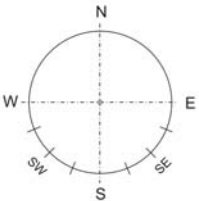
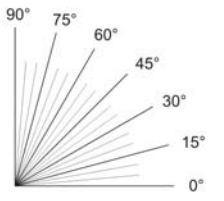
<p><b>Location</b></p> <p>Azimuth</p> 	<p>Slope</p> 	<p><b>Application</b></p> <p><input type="checkbox"/> Domestic Hot Water</p> <p><input type="checkbox"/> Heating Support</p> <p><input type="checkbox"/> Pool Heating</p> <p><input type="checkbox"/> Commercial/Industrial Application _____</p> <p><input type="checkbox"/> Thermal Refrigeration _____</p>
---	--	---

**System**

Storage Tank Overall Capacity _____ l	Expansion Vessel Capacity _____ l	Frost Protection Type _____
Solar Capacity _____ l	Pre-Pressure _____ bar	Temperature _____ °C
	Cold Fill Pressure _____ bar	Safety Valve Opening Pressure _____ bar
Control Manufacturer _____	Settings ΔT _____ K	
Type _____	Tank_Max _____ °C	
Flow Rate <input type="checkbox"/> Fixed _____ l/min	Others _____	
<input type="checkbox"/> Variable	_____	
Vacuum Tube Function <input type="checkbox"/> Yes	Copy of Controller Manual Left with Customer <input type="checkbox"/> Yes	
<input type="checkbox"/> No	<input type="checkbox"/> No	

F

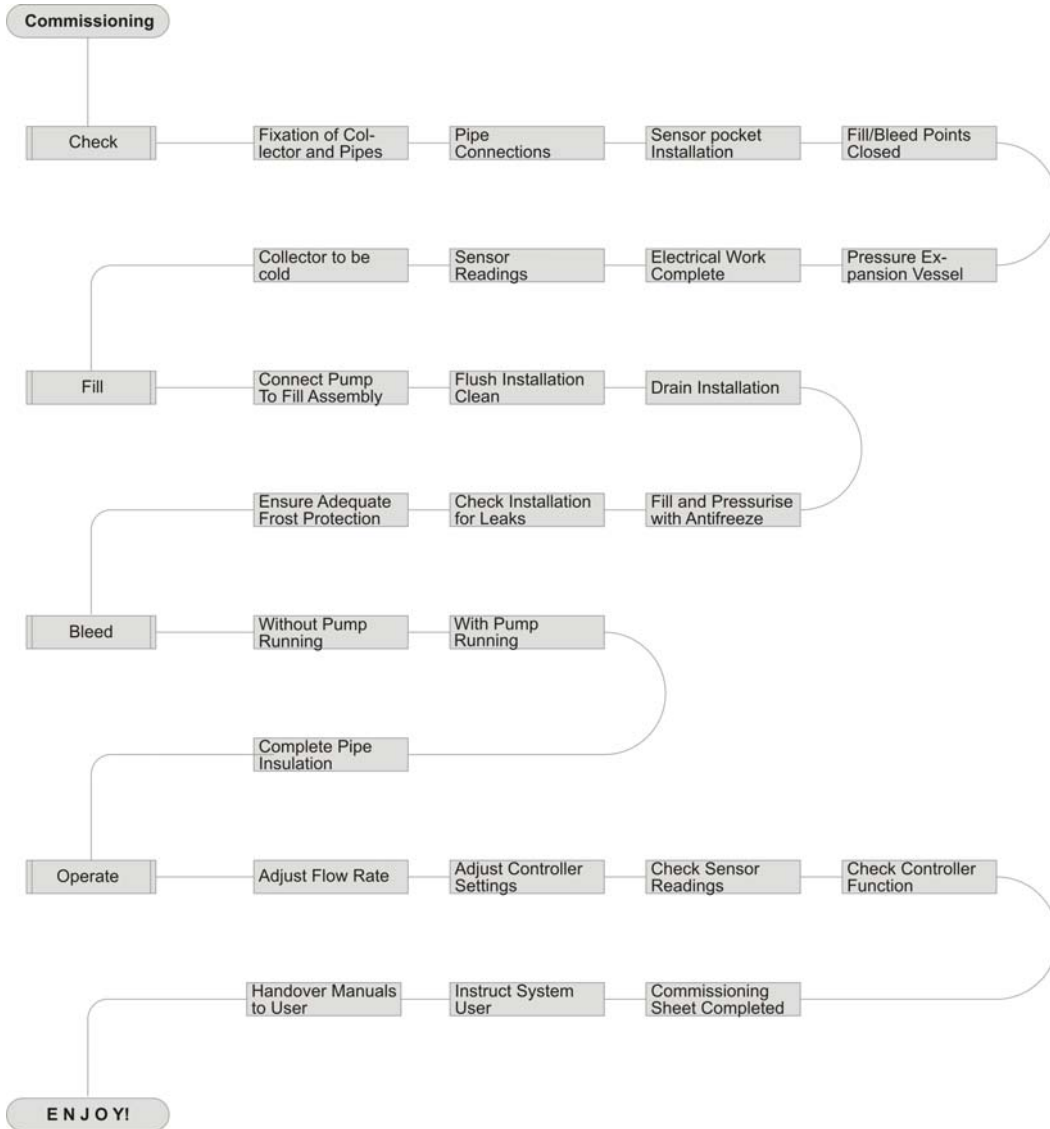

**Commissioning Record** Date \_\_\_/\_\_\_/\_\_\_

**Collector**

Type	Manifold	Tube
<input type="checkbox"/> DF 100	No. of 2m <sup>2</sup> _____	No. in parallel _____
<input type="checkbox"/> HP 100	3m <sup>2</sup> _____	No. in series _____
<input type="checkbox"/> HP 200	Serial No. 2m <sup>2</sup> _____	Serial No. _____
	3m <sup>2</sup> _____	_____

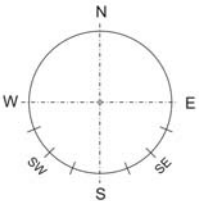
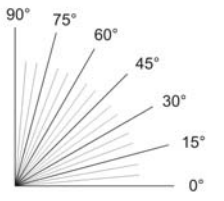
<p><b>Location</b></p> <p>Azimuth</p> 	<p>Slope</p> 	<p><b>Application</b></p> <p><input type="checkbox"/> Domestic Hot Water</p> <p><input type="checkbox"/> Heating Support</p> <p><input type="checkbox"/> Pool Heating</p> <p><input type="checkbox"/> Commercial/Industrial Application _____</p> <p><input type="checkbox"/> Thermal Refrigeration _____</p>
---	--	---

**System**

Storage Tank Overall Capacity _____ l	Expansion Vessel Capacity _____ l	Frost Protection Type _____
Solar Capacity _____ l	Pre-Pressure _____ bar	Temperature _____ °C
	Cold Fill Pressure _____ bar	Safety Valve Opening Pressure _____ bar
Control Manufacturer _____	Settings ΔT _____ K	
Type _____	Tank_Max _____ °C	
Flow Rate <input type="checkbox"/> Fixed _____ l / min	Others _____	
<input type="checkbox"/> Variable	_____	
Vacuum Tube Function <input type="checkbox"/> Yes	Copy of Controller Manual Left with Customer <input type="checkbox"/> Yes	
<input type="checkbox"/> No	<input type="checkbox"/> No	

**Warranty Card**

Date \_\_\_ / \_\_\_ / \_\_\_

**Collector**

Type	Manifold		Tube
<input type="checkbox"/> DF 100	No. of	2m <sup>2</sup> _____	No. in parallel _____
<input type="checkbox"/> HP 100		3m <sup>2</sup> _____	No. in series _____
<input type="checkbox"/> HP 200	Serial No.	2m <sup>2</sup> _____	Serial No. _____
		3m <sup>2</sup> _____	_____

**Location**

Azimuth

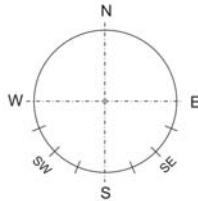

Slope

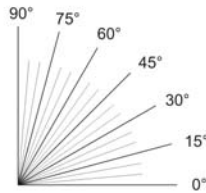

**Application**

Domestic Hot Water

Heating Support

Pool Heating

Commercial/Industrial Application \_\_\_\_\_

Thermal Refrigeration \_\_\_\_\_

**System**

Storage Tank Overall Capacity _____ l	Expansion Vessel Capacity _____ l	Frost Protection Type _____
Solar Capacity _____ l	Pre-Pressure _____ bar	Temperature _____ °C
	Cold Fill Pressure _____ bar	Safety Valve Opening Pressure _____ bar
Control Manufacturer _____	Settings ΔT _____ K	
Type _____	Tank_Max _____ °C	
Flow Rate <input type="checkbox"/> Fixed _____ l / min	Others _____	
<input type="checkbox"/> Variable	_____	
Vacuum Tube Function <input type="checkbox"/> Yes	Copy of Controller Manual Left with Customer <input type="checkbox"/> Yes	
<input type="checkbox"/> No	<input type="checkbox"/> No	

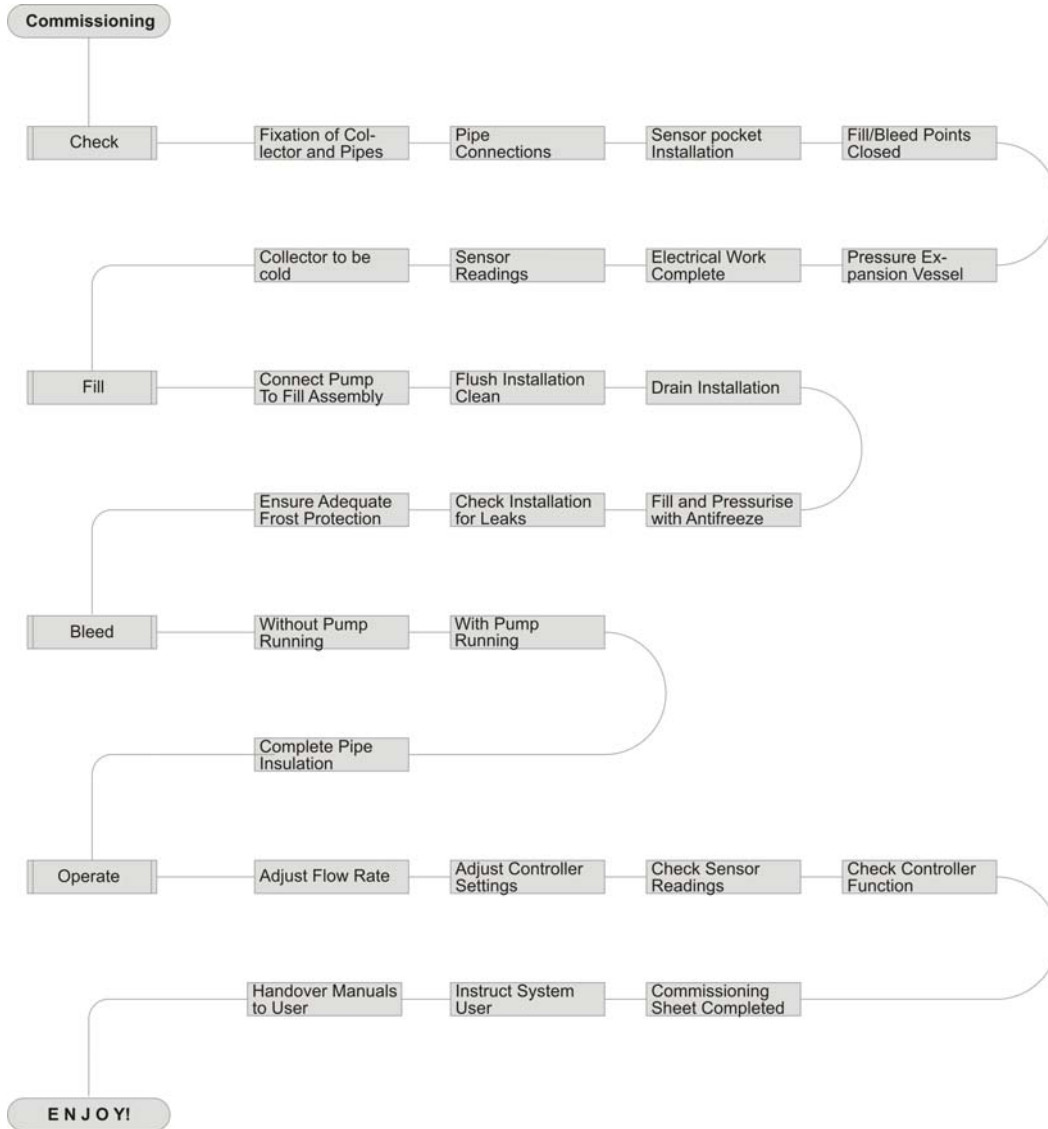

## Commissioning Record

Date \_\_\_ / \_\_\_ / \_\_\_

## Collector

Type	Manifold		Tube
<input type="checkbox"/> DF 100	No. of	2m <sup>2</sup> _____	No. in parallel _____
<input type="checkbox"/> HP 100		3m <sup>2</sup> _____	No. in series _____
<input type="checkbox"/> HP 200	Serial No.	2m <sup>2</sup> _____	Serial No. _____
		3m <sup>2</sup> _____	_____

## Location

Azimuth

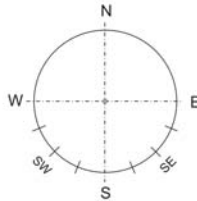

Slope

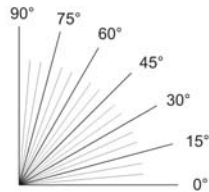

## Application

- Domestic Hot Water
- Heating Support
- Pool Heating
- Commercial/Industrial Application \_\_\_\_\_
- Thermal Refrigeration \_\_\_\_\_

## System

Storage Tank	Overall Capacity _____ l	Expansion Vessel Capacity _____ l	Frost Protection Type _____
	Solar Capacity _____ l	Pre-Pressure _____ bar	Temperature _____ °C
		Cold Fill Pressure _____ bar	Safety Valve Opening Pressure _____ bar
Control	Manufacturer _____	Settings $\Delta T$ _____ K	
	Type _____	Tank_Max _____ °C	
	Flow Rate <input type="checkbox"/> Fixed _____ l / min	Others _____	
	<input type="checkbox"/> Variable	_____	
	Vacuum Tube Function <input type="checkbox"/> Yes	Copy of Controller Manual Left with Customer <input type="checkbox"/> Yes	
	<input type="checkbox"/> No	<input type="checkbox"/> No	

**Warranty Card** Date \_\_\_/\_\_\_/\_\_\_

**Collector**

Type	Manifold		Tube
<input type="checkbox"/> DF 100	No. of	2m <sup>2</sup> _____	No. in parallel _____
<input type="checkbox"/> HP 100		3m <sup>2</sup> _____	No. in series _____
<input type="checkbox"/> HP 200	Serial No.	2m <sup>2</sup> _____	Serial No. _____
		3m <sup>2</sup> _____	_____

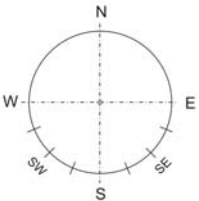
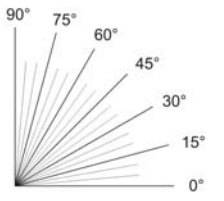
Location	Application
<p>Azimuth</p>  <p>Slope</p> 	<input type="checkbox"/> Domestic Hot Water <input type="checkbox"/> Heating Support <input type="checkbox"/> Pool Heating <input type="checkbox"/> Commercial/Industrial Application _____ <input type="checkbox"/> Thermal Refrigeration _____

**System**

Storage Tank Overall Capacity _____ l	Expansion Vessel Capacity _____ l	Frost Protection Type _____
Solar Capacity _____ l	Pre-Pressure _____ bar	Temperature _____ °C
	Cold Fill Pressure _____ bar	Safety Valve Opening Pressure _____ bar
Control Manufacturer _____	Settings $\Delta T$ _____ K	
Type _____	Tank_Max _____ °C	
Flow Rate <input type="checkbox"/> Fixed _____ l / min	Others _____	
<input type="checkbox"/> Variable	_____	
Vacuum Tube Function <input type="checkbox"/> Yes	Copy of Controller Manual Left with Customer <input type="checkbox"/> Yes	
<input type="checkbox"/> No	<input type="checkbox"/> No	

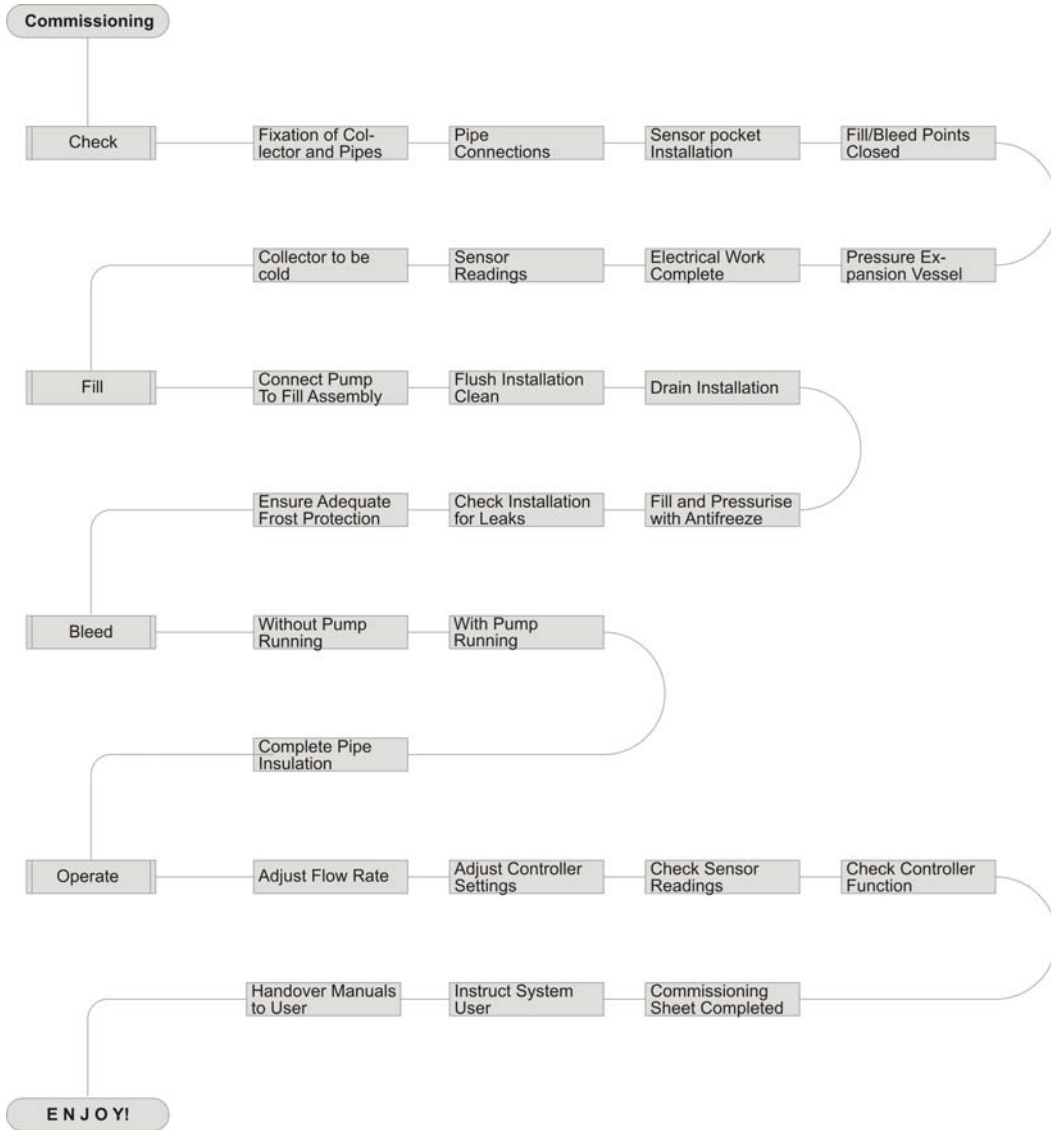

**Commissioning Record** Date \_\_\_/\_\_\_/\_\_\_

**Collector**

Type	Manifold		Tube
<input type="checkbox"/> DF 100	No. of	2m <sup>2</sup> _____	No. in parallel _____
<input type="checkbox"/> HP 100		3m <sup>2</sup> _____	No. in series _____
<input type="checkbox"/> HP 200	Serial No.	2m <sup>2</sup> _____	Serial No. _____
		3m <sup>2</sup> _____	_____

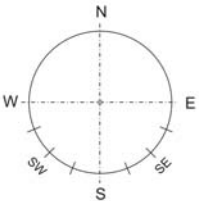
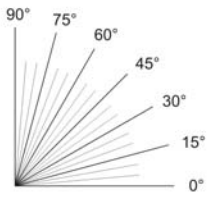
<p><b>Location</b></p> <p>Azimuth</p> 	<p>Slope</p> 	<p><b>Application</b></p> <p><input type="checkbox"/> Domestic Hot Water</p> <p><input type="checkbox"/> Heating Support</p> <p><input type="checkbox"/> Pool Heating</p> <p><input type="checkbox"/> Commercial/Industrial Application _____</p> <p><input type="checkbox"/> Thermal Refrigeration _____</p>
---	--	---

**System**

Storage Tank Overall Capacity _____ l	Expansion Vessel Capacity _____ l	Frost Protection Type _____
Solar Capacity _____ l	Pre-Pressure _____ bar	Temperature _____ °C
	Cold Fill Pressure _____ bar	Safety Valve Opening Pressure _____ bar
Control Manufacturer _____	Settings ΔT _____ K	
Type _____	Tank_Max _____ °C	
Flow Rate <input type="checkbox"/> Fixed _____ l/min	Others _____	
<input type="checkbox"/> Variable	_____	
Vacuum Tube Function <input type="checkbox"/> Yes	Copy of Controller Manual Left with Customer <input type="checkbox"/> Yes	
<input type="checkbox"/> No	<input type="checkbox"/> No	

**Warranty Card**

Date \_\_\_ / \_\_\_ / \_\_\_

**Collector**

Type	Manifold		Tube
<input type="checkbox"/> DF 100	No. of	2m <sup>2</sup> _____	No. in parallel _____
<input type="checkbox"/> HP 100		3m <sup>2</sup> _____	No. in series _____
<input type="checkbox"/> HP 200	Serial No.	2m <sup>2</sup> _____	Serial No. _____
		3m <sup>2</sup> _____	_____

**Location**

Azimuth

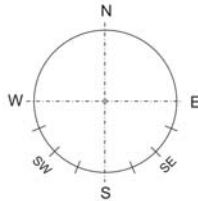

Slope

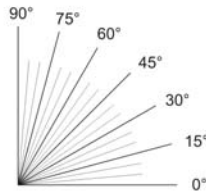

**Application**

Domestic Hot Water

Heating Support

Pool Heating

Commercial/Industrial Application \_\_\_\_\_

Thermal Refrigeration \_\_\_\_\_

**System**

Storage Tank	Overall Capacity _____ l	Expansion Vessel Capacity _____ l	Frost Protection Type _____
	Solar Capacity _____ l	Pre-Pressure _____ bar	Temperature _____ °C
		Cold Fill Pressure _____ bar	Safety Valve Opening Pressure _____ bar
Control	Manufacturer _____	Settings $\Delta T$ _____ K	
	Type _____	Tank_Max _____ °C	
	Flow Rate <input type="checkbox"/> Fixed _____ l / min	Others _____	
	<input type="checkbox"/> Variable	_____	
	Vacuum Tube Function <input type="checkbox"/> Yes	Copy of Controller Manual Left with Customer <input type="checkbox"/> Yes	
	<input type="checkbox"/> No	<input type="checkbox"/> No	

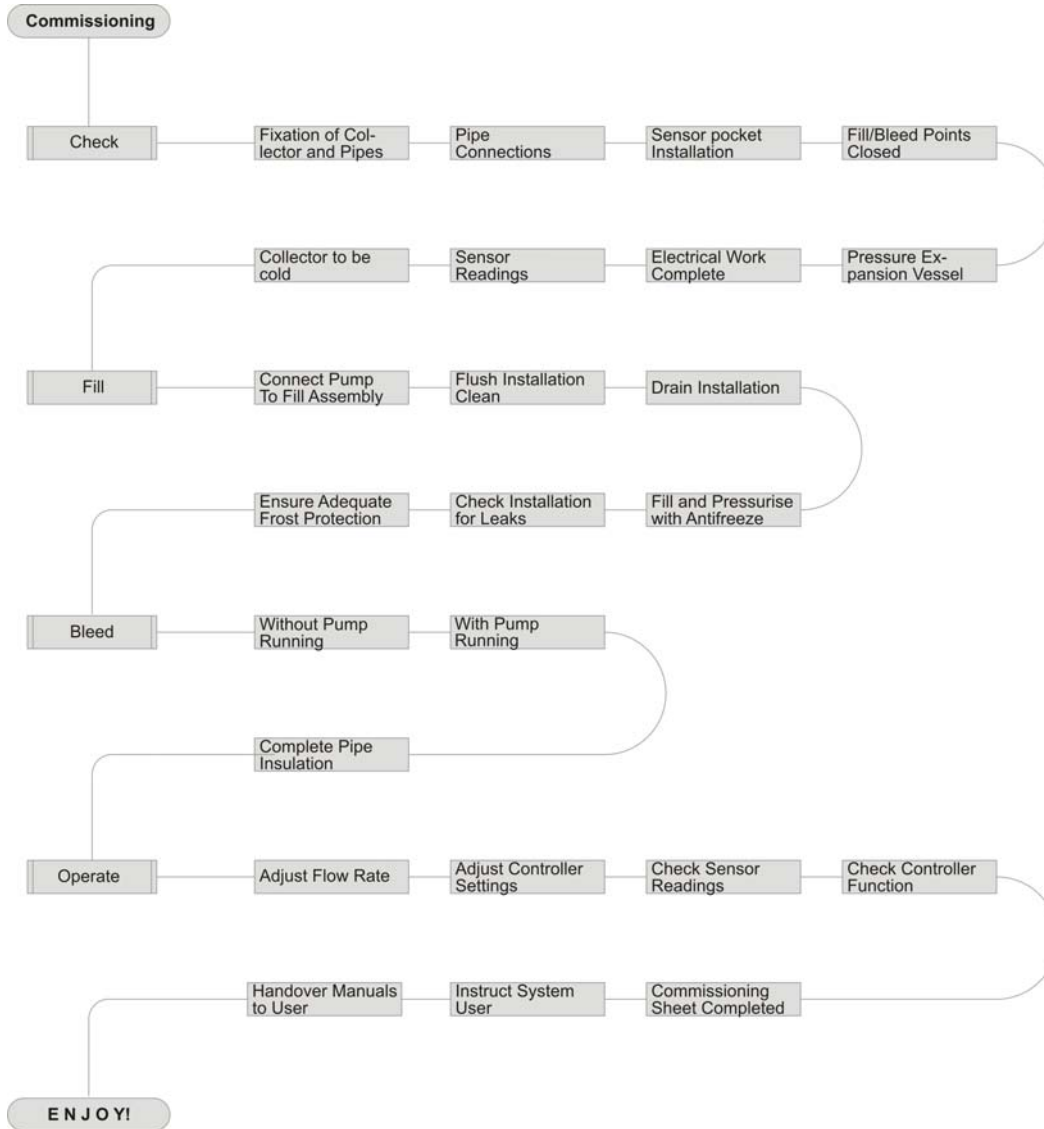

## Commissioning Record

Date \_\_\_ / \_\_\_ / \_\_\_

## Collector

Type	Manifold	Tube
<input type="checkbox"/> DF 100	No. of 2m <sup>2</sup> _____	No. in parallel _____
<input type="checkbox"/> HP 100	3m <sup>2</sup> _____	No. in series _____
<input type="checkbox"/> HP 200	Serial No. 2m <sup>2</sup> _____	Serial No. _____
	3m <sup>2</sup> _____	_____

## Location

Azimuth

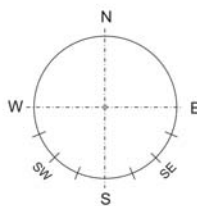

Slope

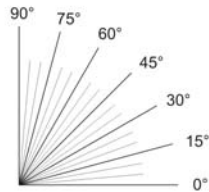

## Application

<input type="checkbox"/> Domestic Hot Water	_____
<input type="checkbox"/> Heating Support	_____
<input type="checkbox"/> Pool Heating	_____
<input type="checkbox"/> Commercial/Industrial Application	_____
<input type="checkbox"/> Thermal Refrigeration	_____

## System

Storage Tank Overall Capacity _____ l	Expansion Vessel Capacity _____ l	Frost Protection Type _____
Solar Capacity _____ l	Pre-Pressure _____ bar	Temperature _____ °C
	Cold Fill Pressure _____ bar	Safety Valve Opening Pressure _____ bar
Control Manufacturer _____	Settings $\Delta T$ _____ K	
Type _____	Tank_Max _____ °C	
Flow Rate <input type="checkbox"/> Fixed _____ l / min	Others _____	
<input type="checkbox"/> Variable	_____	
Vacuum Tube Function <input type="checkbox"/> Yes	Copy of Controller Manual Left with Customer <input type="checkbox"/> Yes	
<input type="checkbox"/> No	<input type="checkbox"/> No	

**Warranty Card**

Date \_\_\_/\_\_\_/\_\_\_

**Collector**

Type	Manifold		Tube
<input type="checkbox"/> DF 100	No. of	2m <sup>2</sup> _____	No. in parallel _____
<input type="checkbox"/> HP 100		3m <sup>2</sup> _____	No. in series _____
<input type="checkbox"/> HP 200	Serial No.	2m <sup>2</sup> _____	Serial No. _____
		3m <sup>2</sup> _____	_____

**Location**

Azimuth

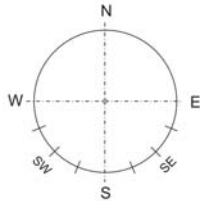

Slope

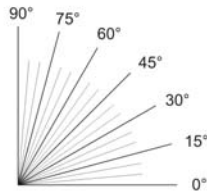

**Application**

- Domestic Hot Water
- Heating Support
- Pool Heating
- Commercial/Industrial Application \_\_\_\_\_
- Thermal Refrigeration \_\_\_\_\_

**System**

Storage Tank Overall Capacity _____ l	Expansion Vessel Capacity _____ l	Frost Protection Type _____
Solar Capacity _____ l	Pre-Pressure _____ bar	Temperature _____ °C
	Cold Fill Pressure _____ bar	Safety Valve Opening Pressure _____ bar
Control Manufacturer _____	Settings ΔT _____ K	
Type _____	Tank_Max _____ °C	
Flow Rate <input type="checkbox"/> Fixed _____ l / min	Others _____	
<input type="checkbox"/> Variable	_____	
Vacuum Tube Function <input type="checkbox"/> Yes	Copy of Controller Manual Left with Customer <input type="checkbox"/> Yes	
<input type="checkbox"/> No	<input type="checkbox"/> No	



**3 Maintenance**

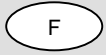

**3 Maintenance**

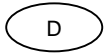

**3 Maintenance**



**3 Maintenance**



**3 Maintenance**













**4 Troubleshooting**



**4 Troubleshooting**

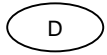

**4 Troubleshooting**



**4 Troubleshooting**



**4 Troubleshooting**

GB

Troubleshooting

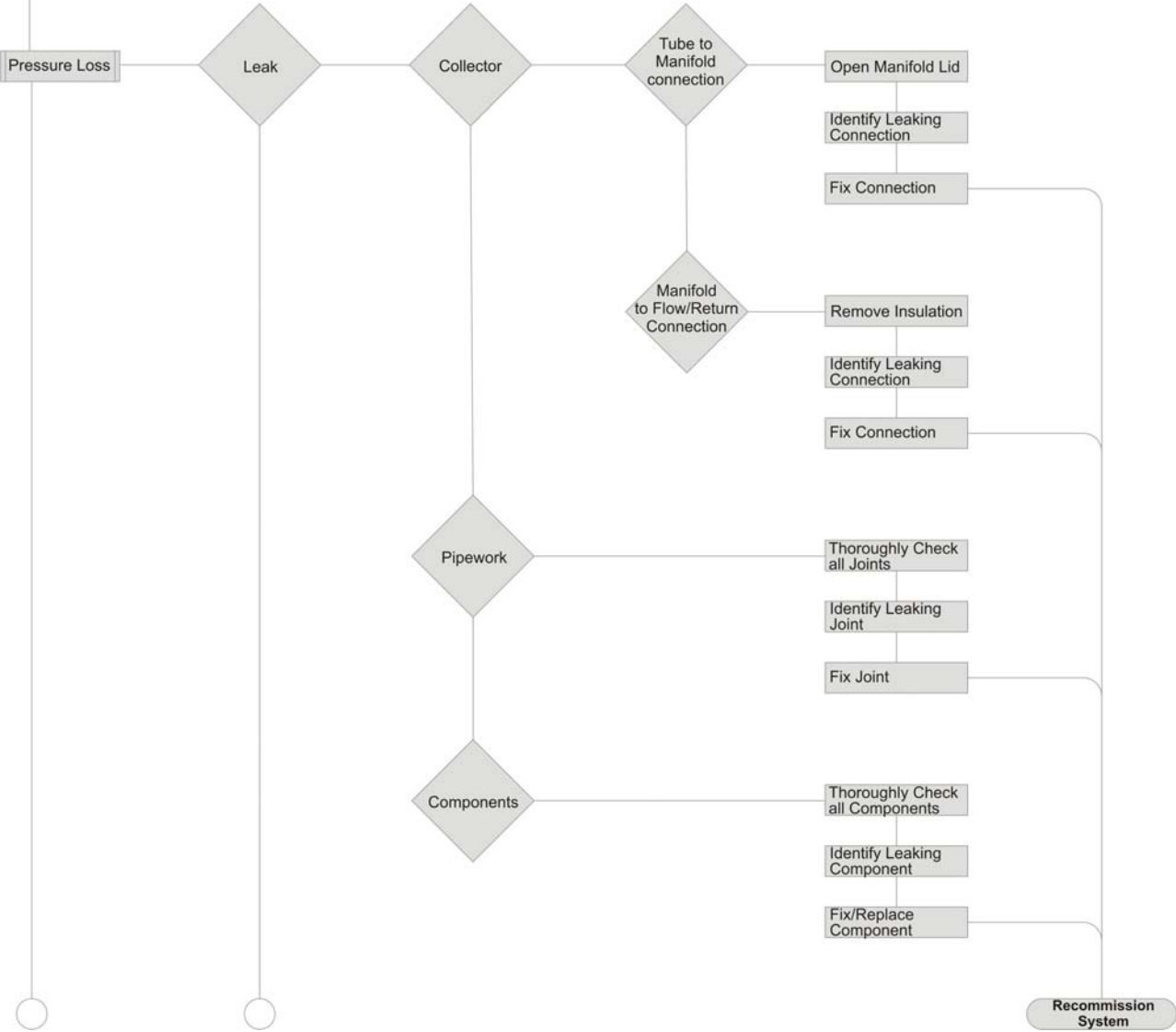

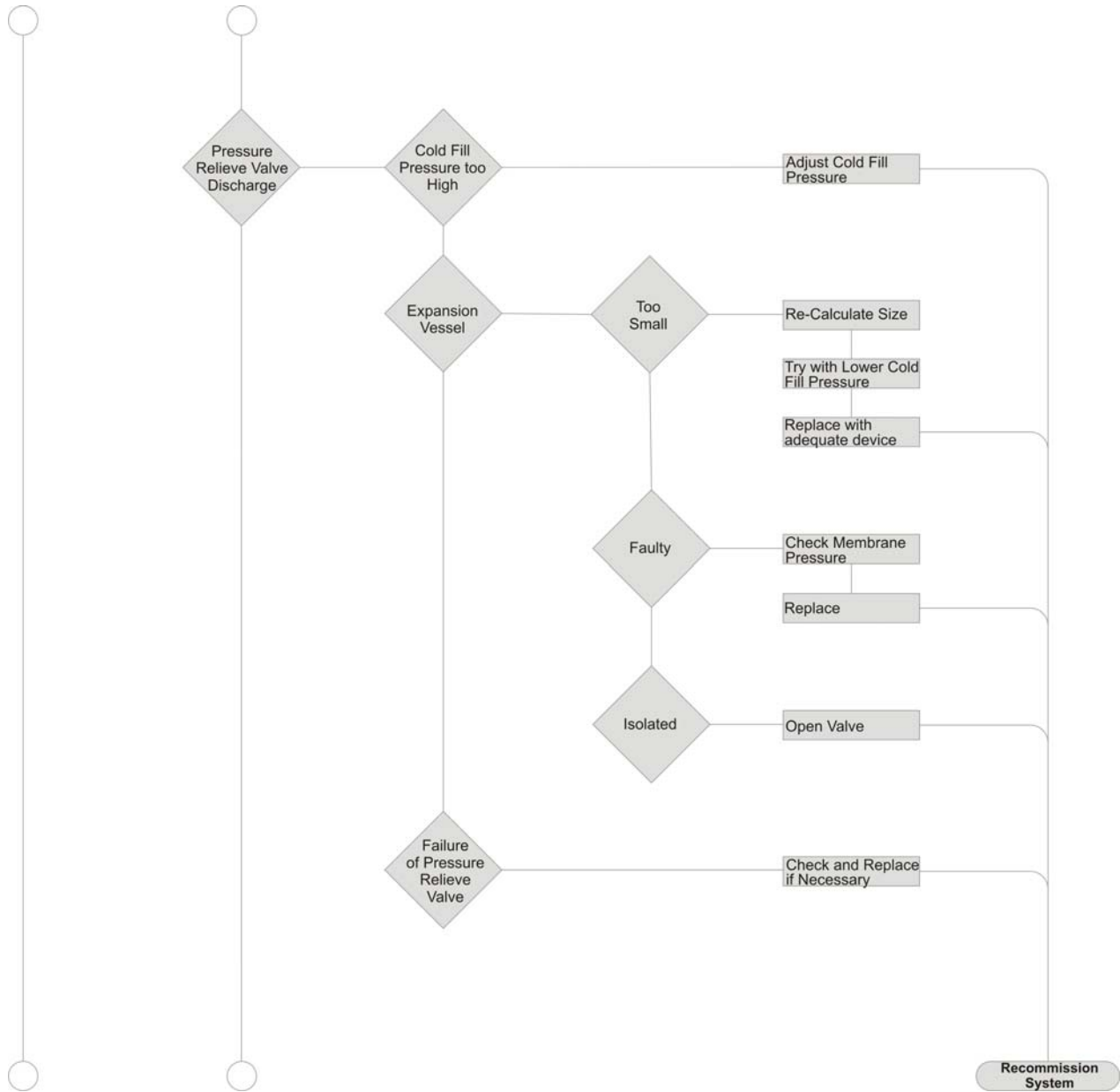

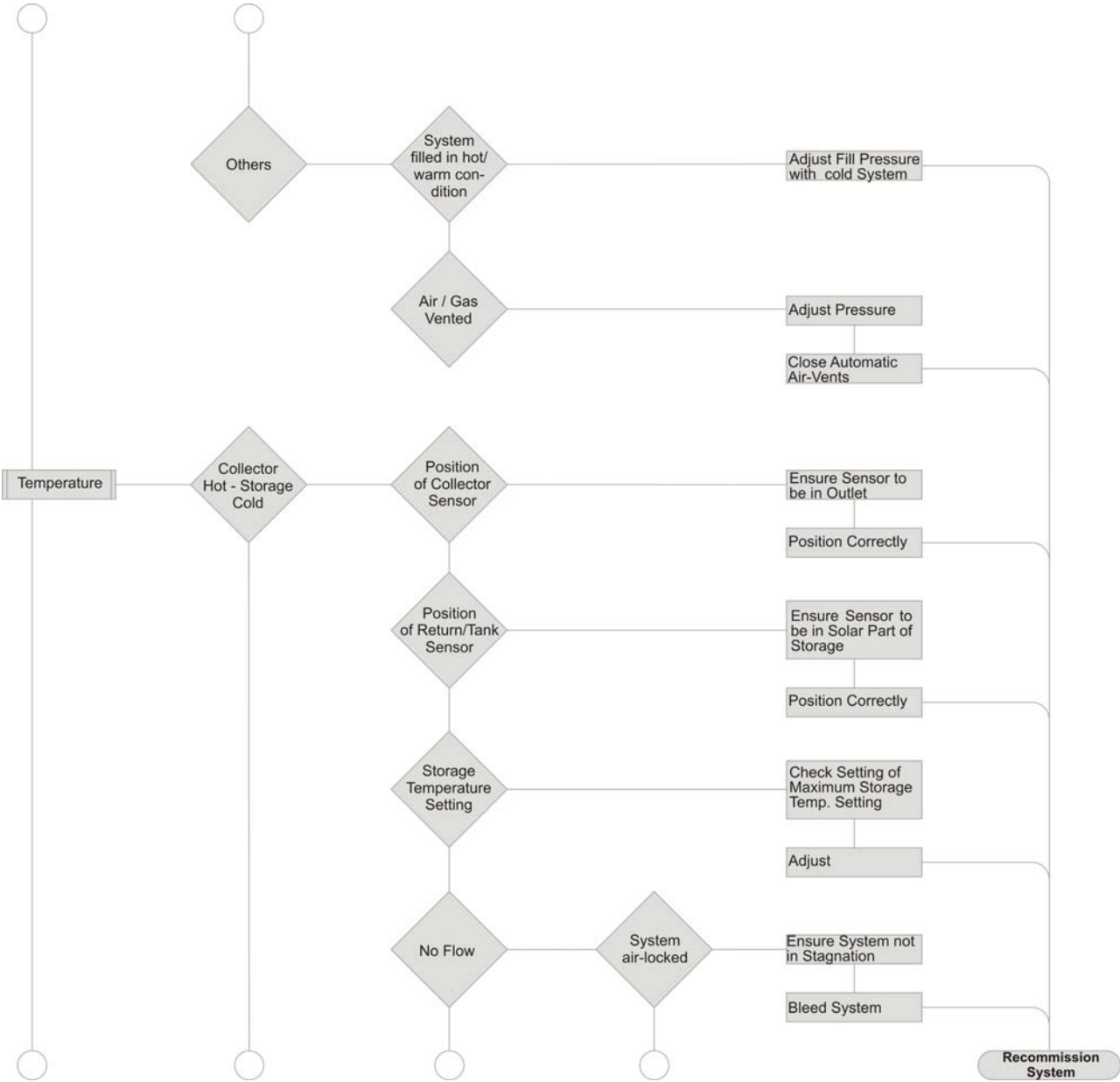

GB

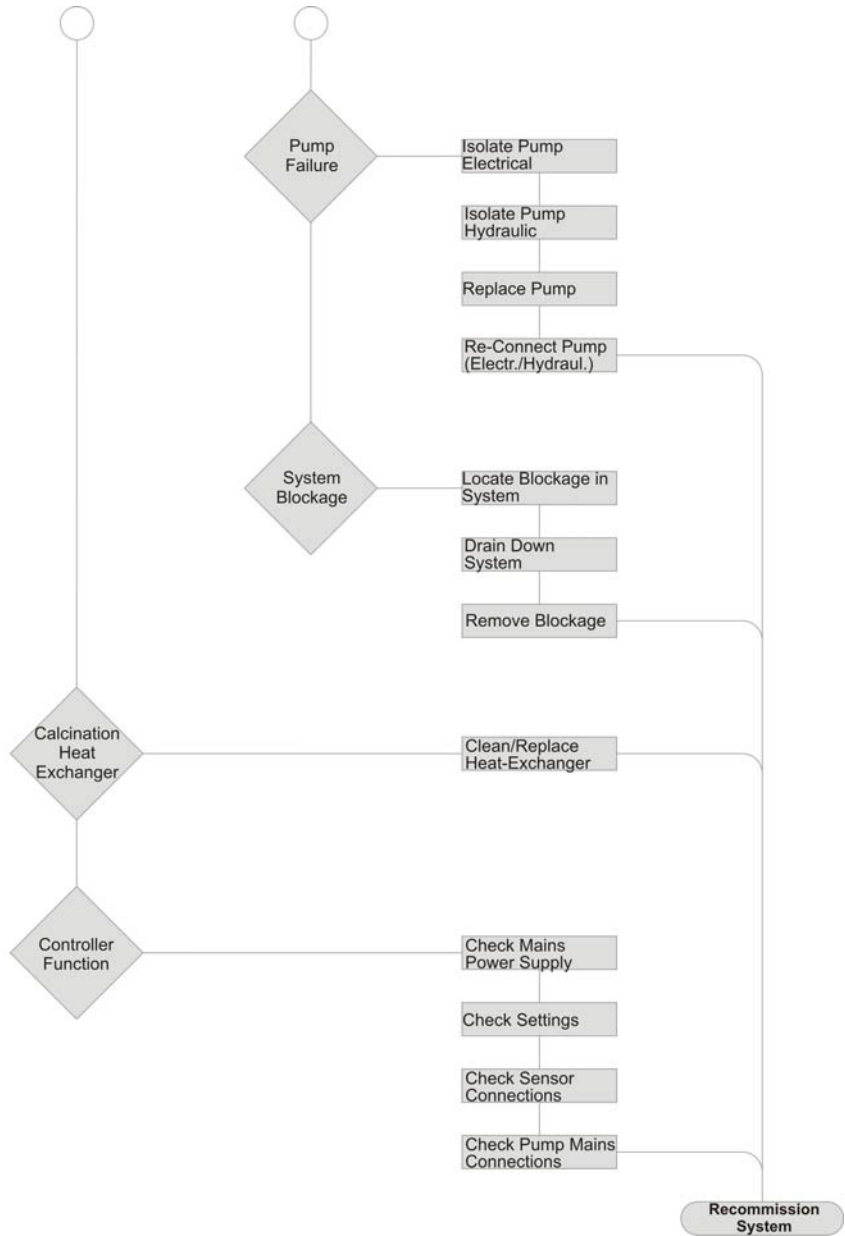

GB

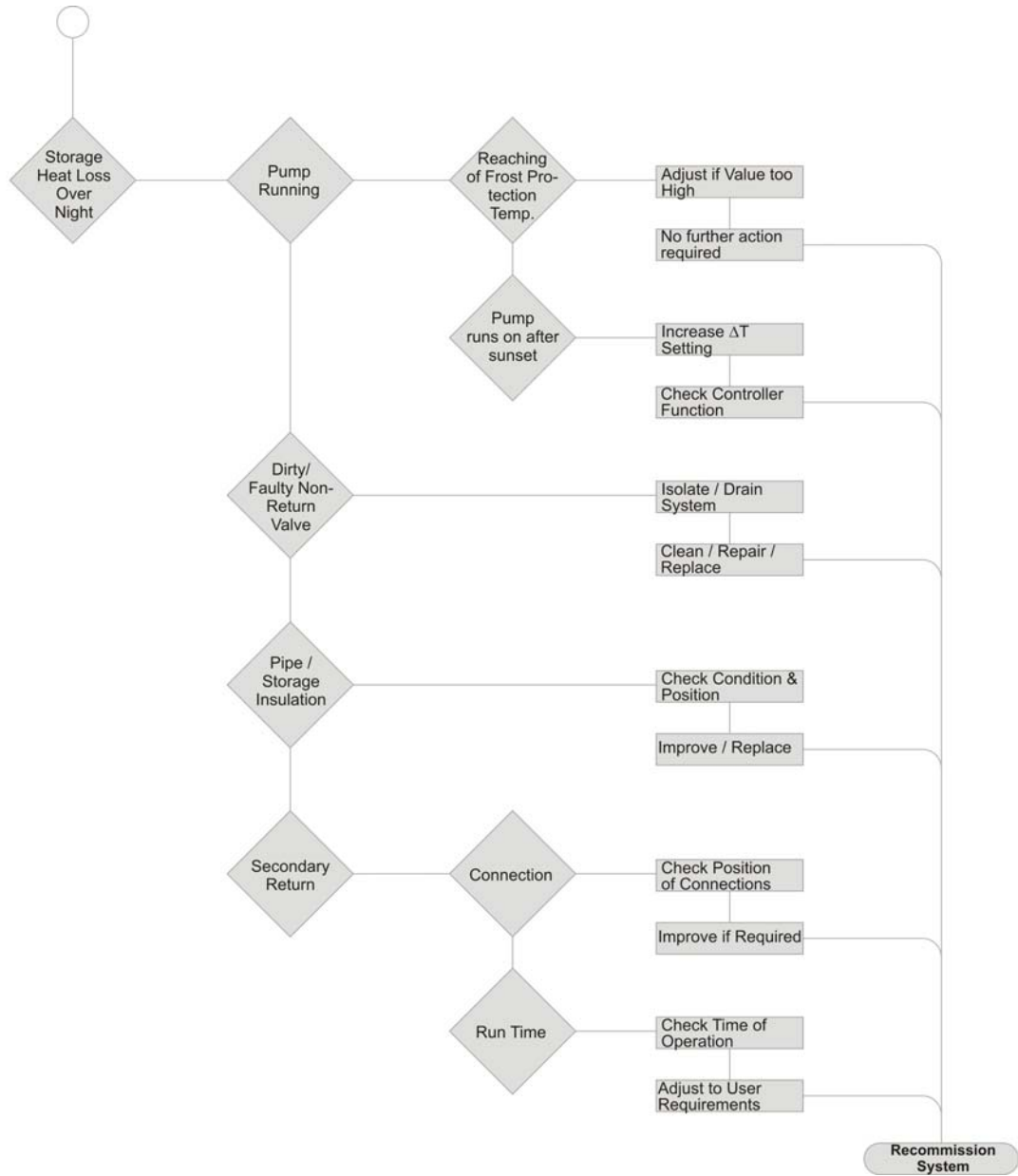

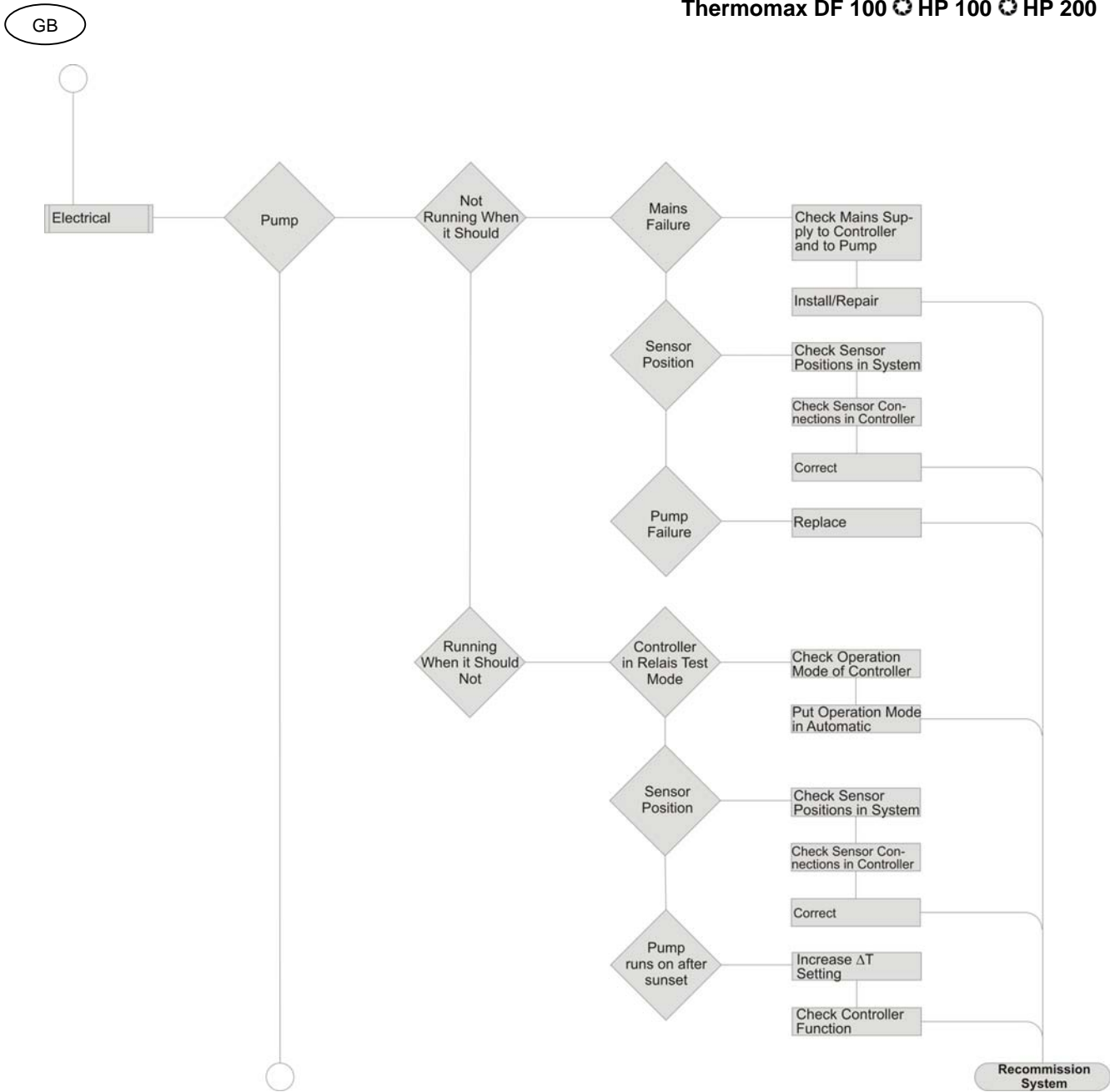

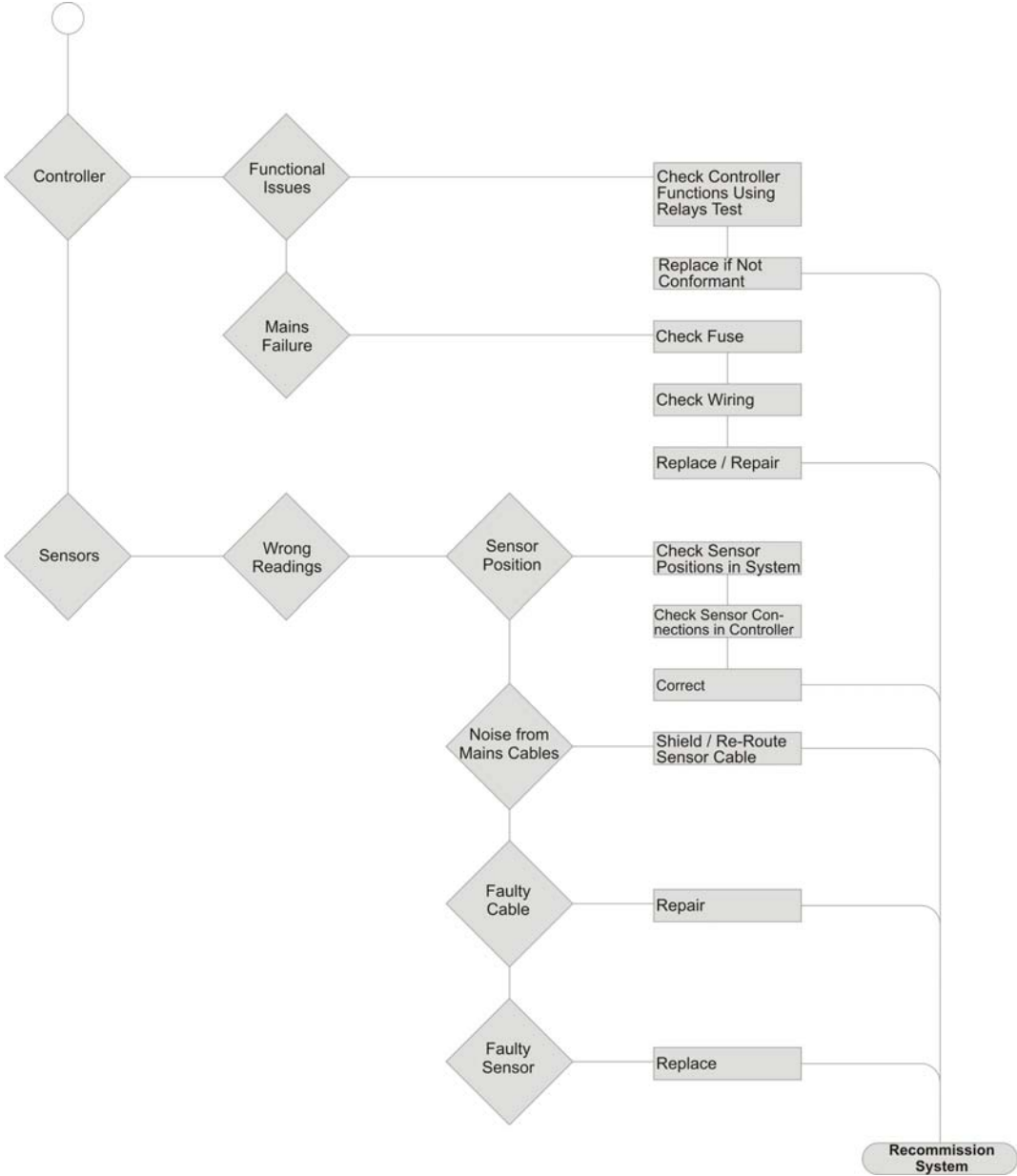

F

Troubleshooting

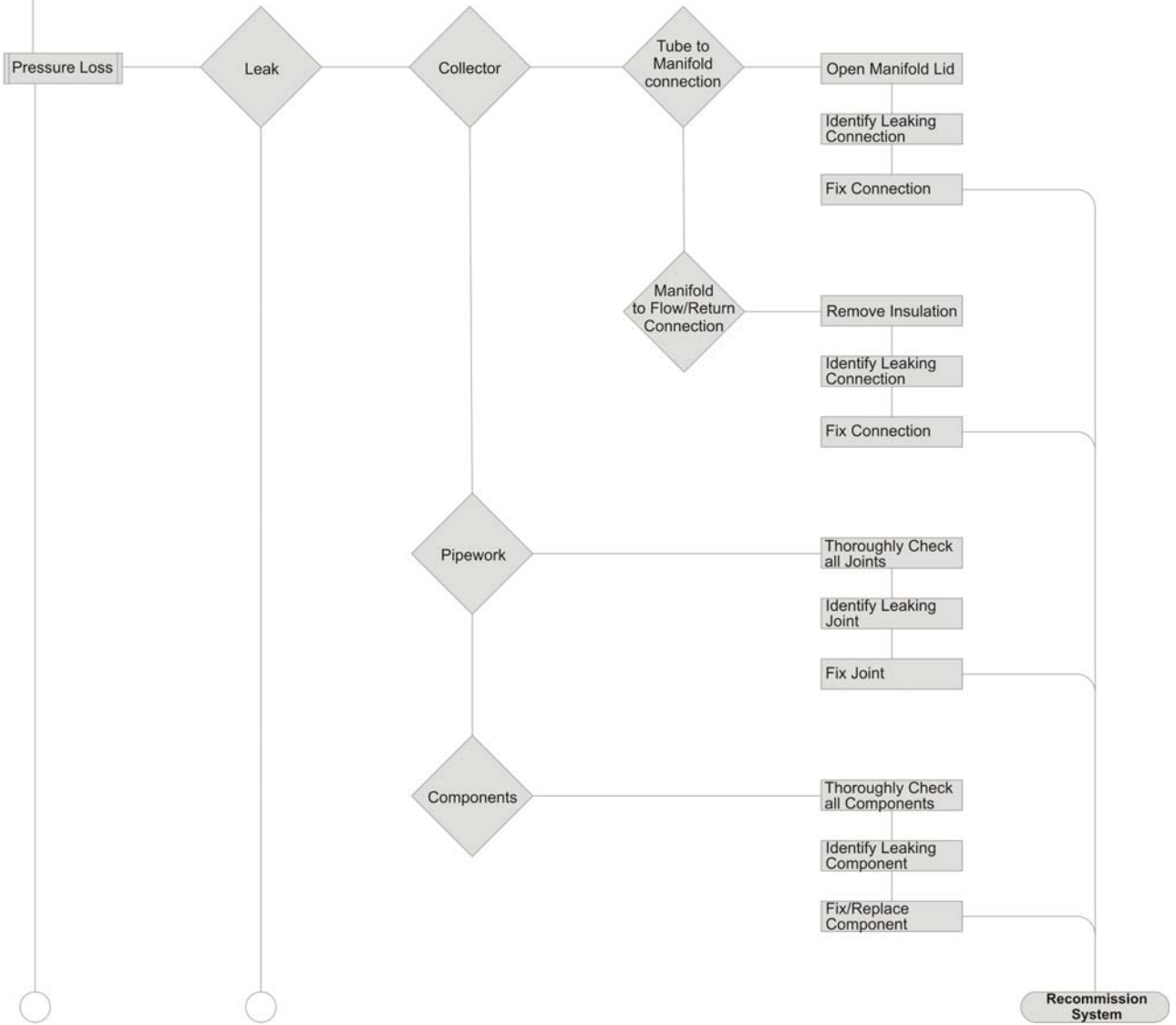

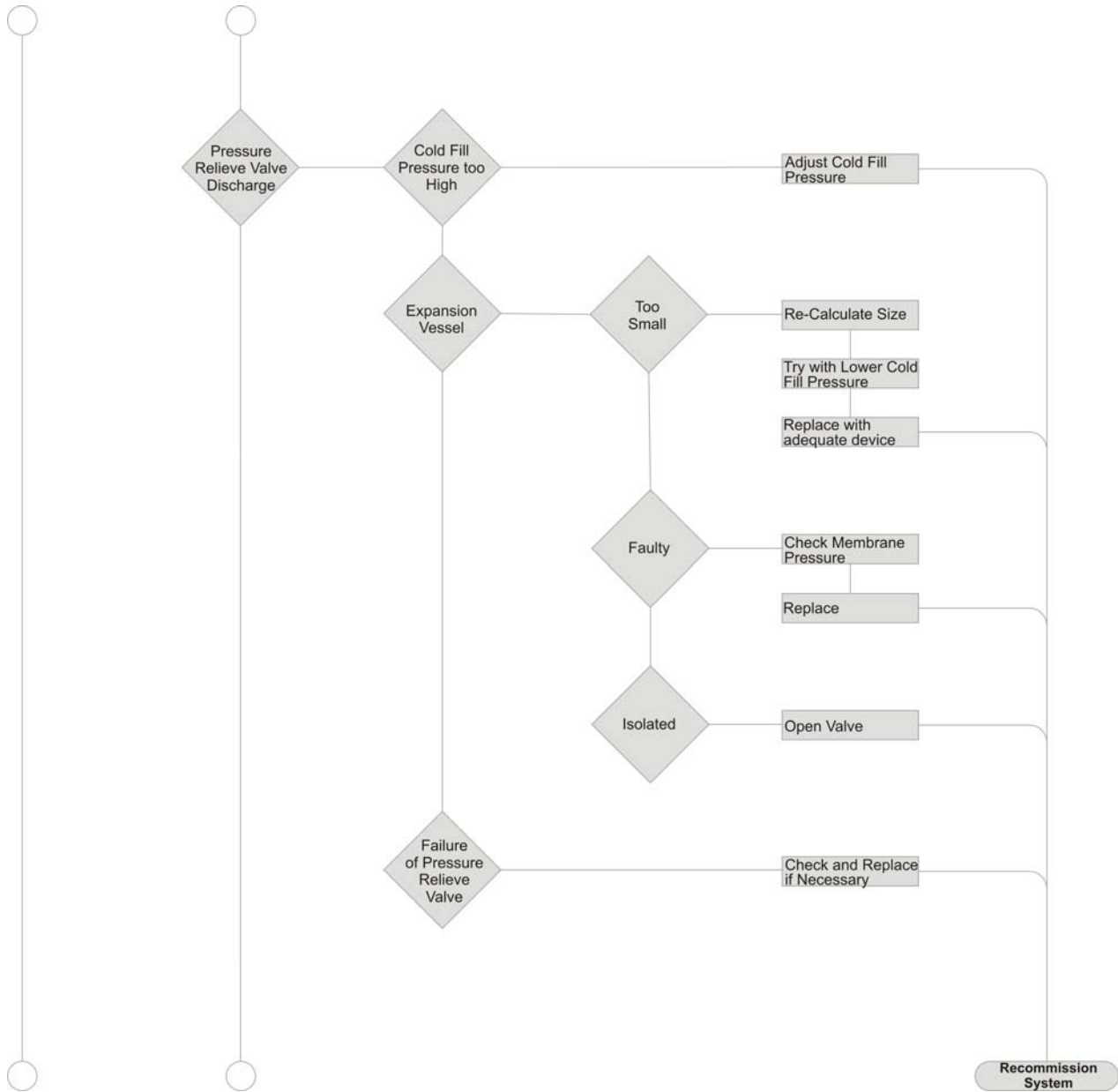

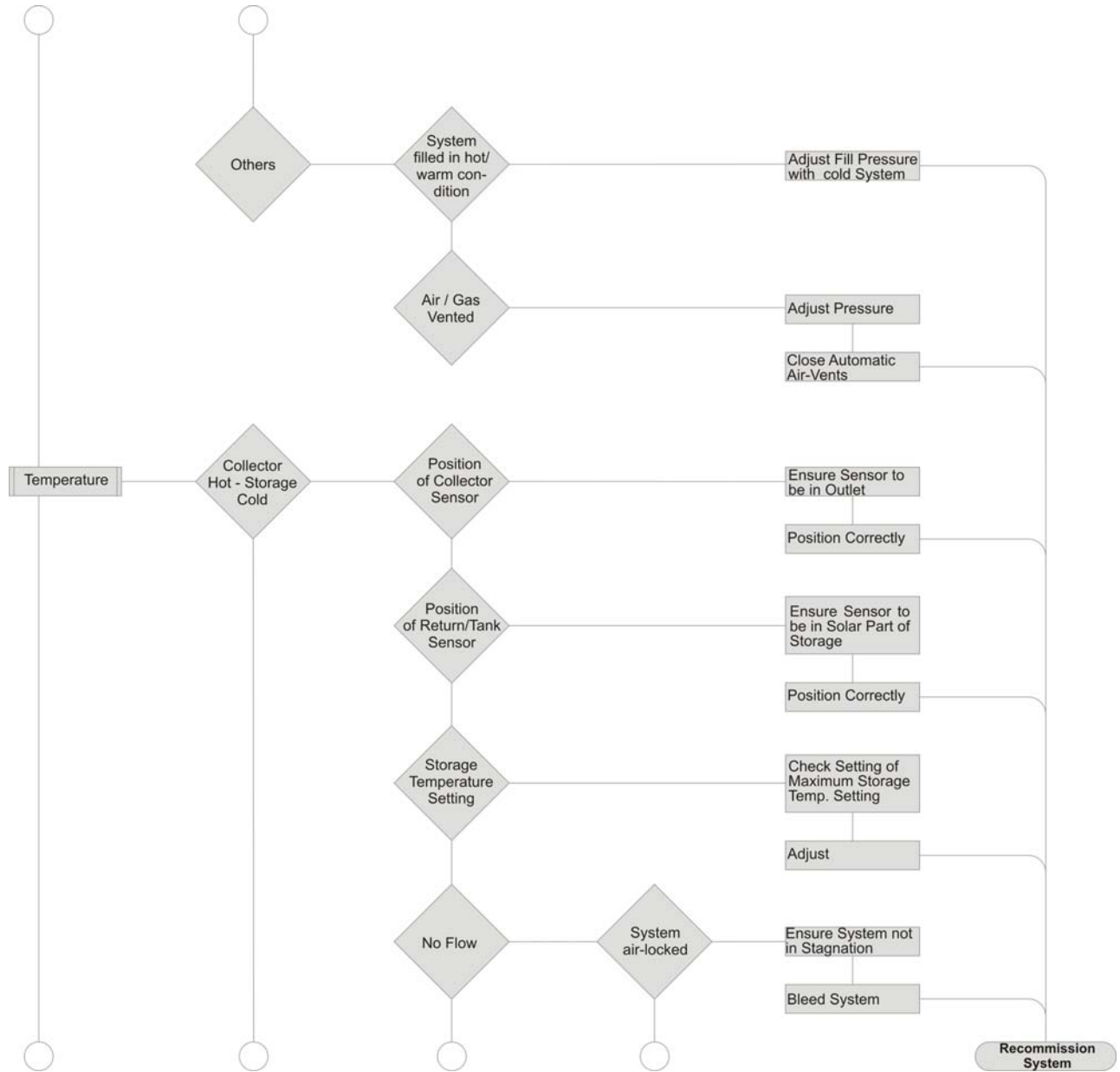

F

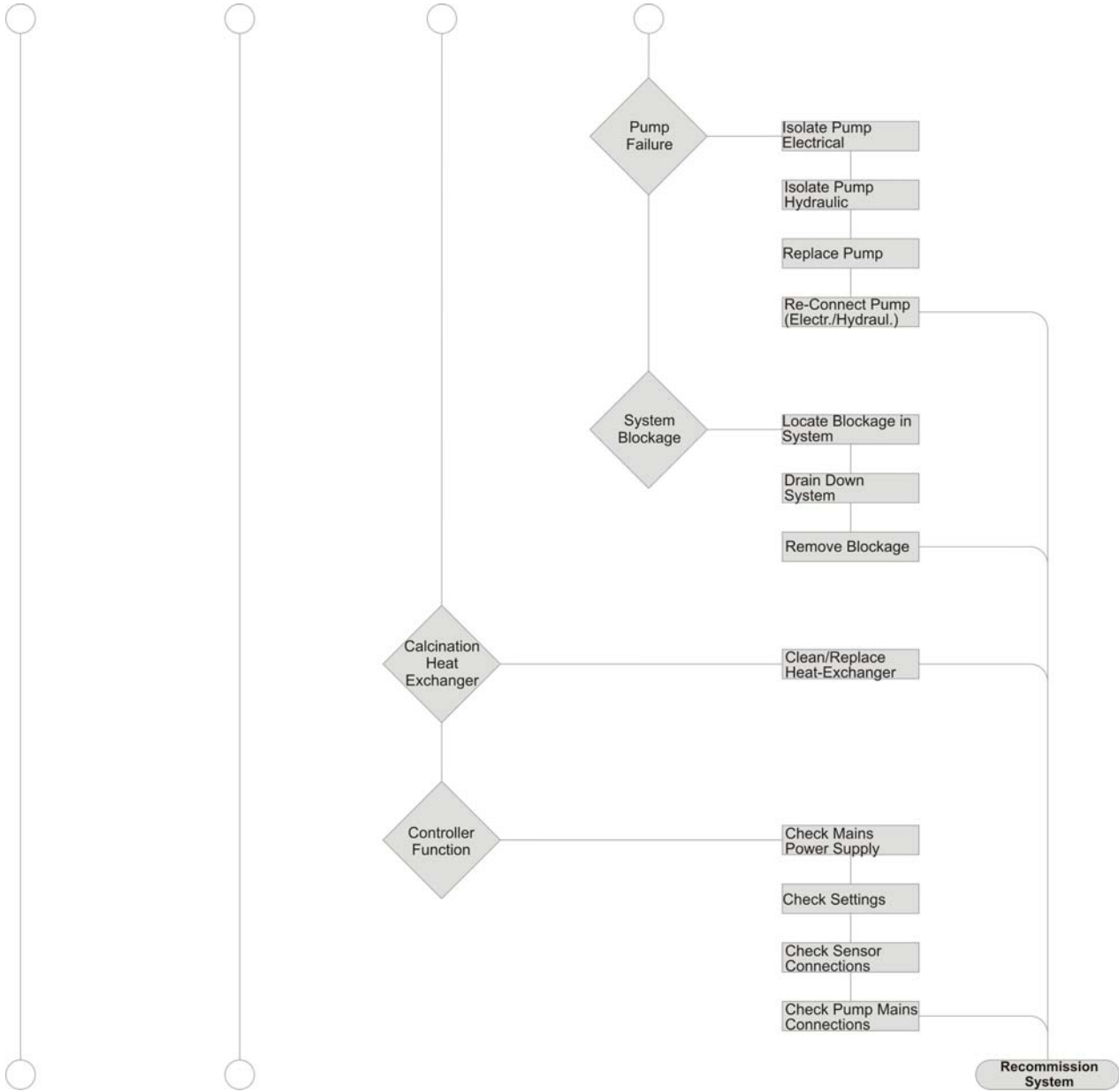

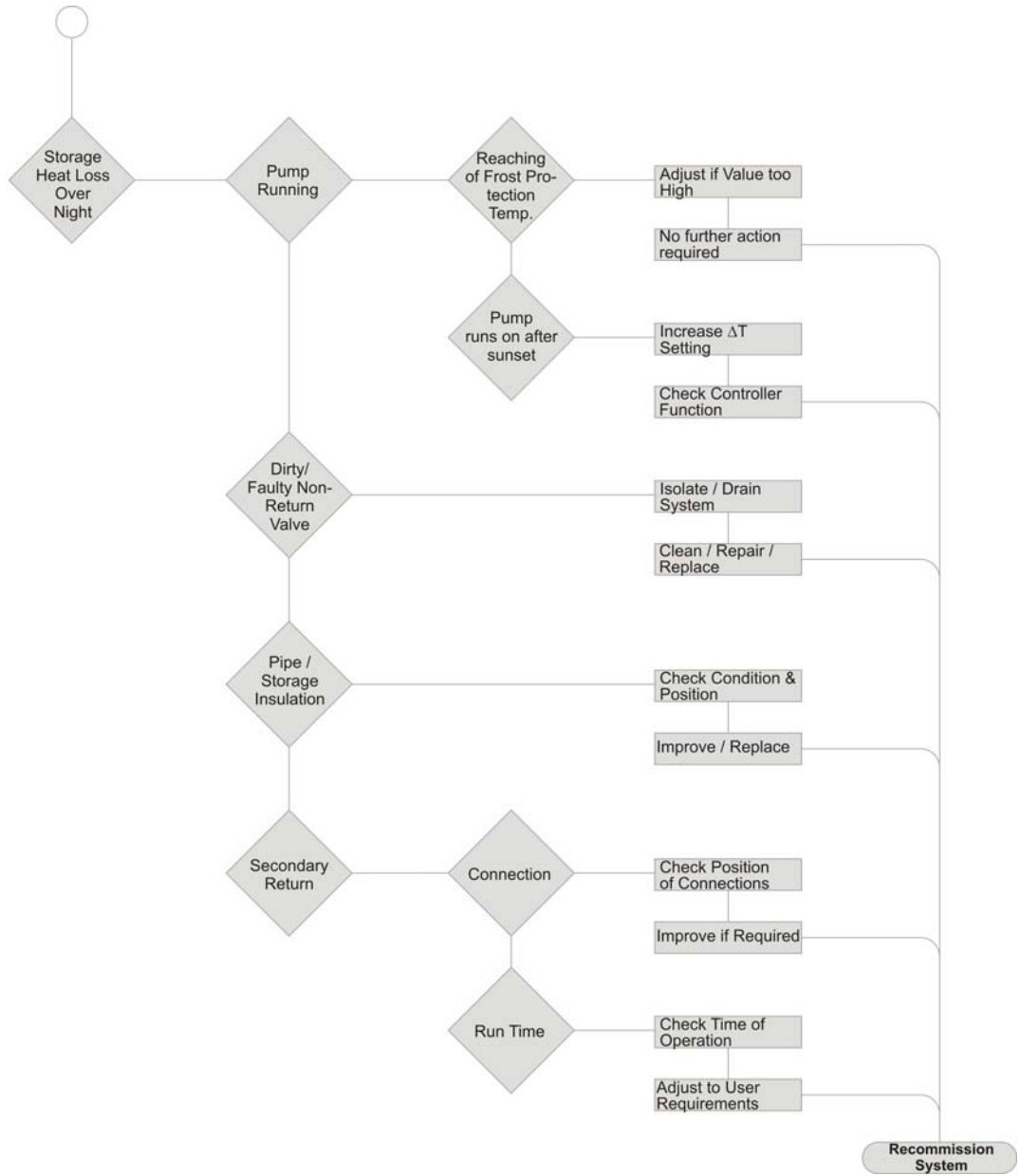

F

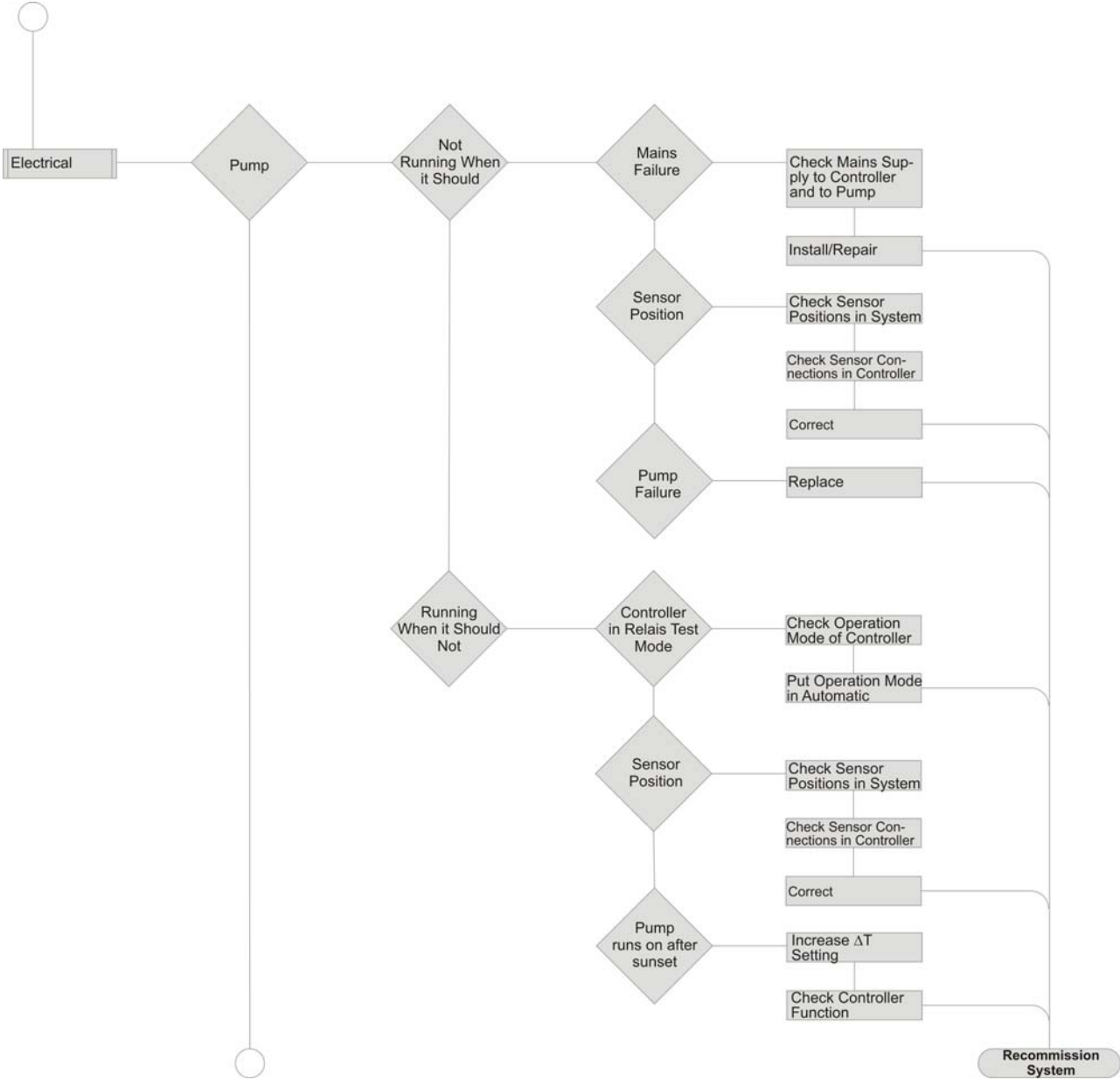

F

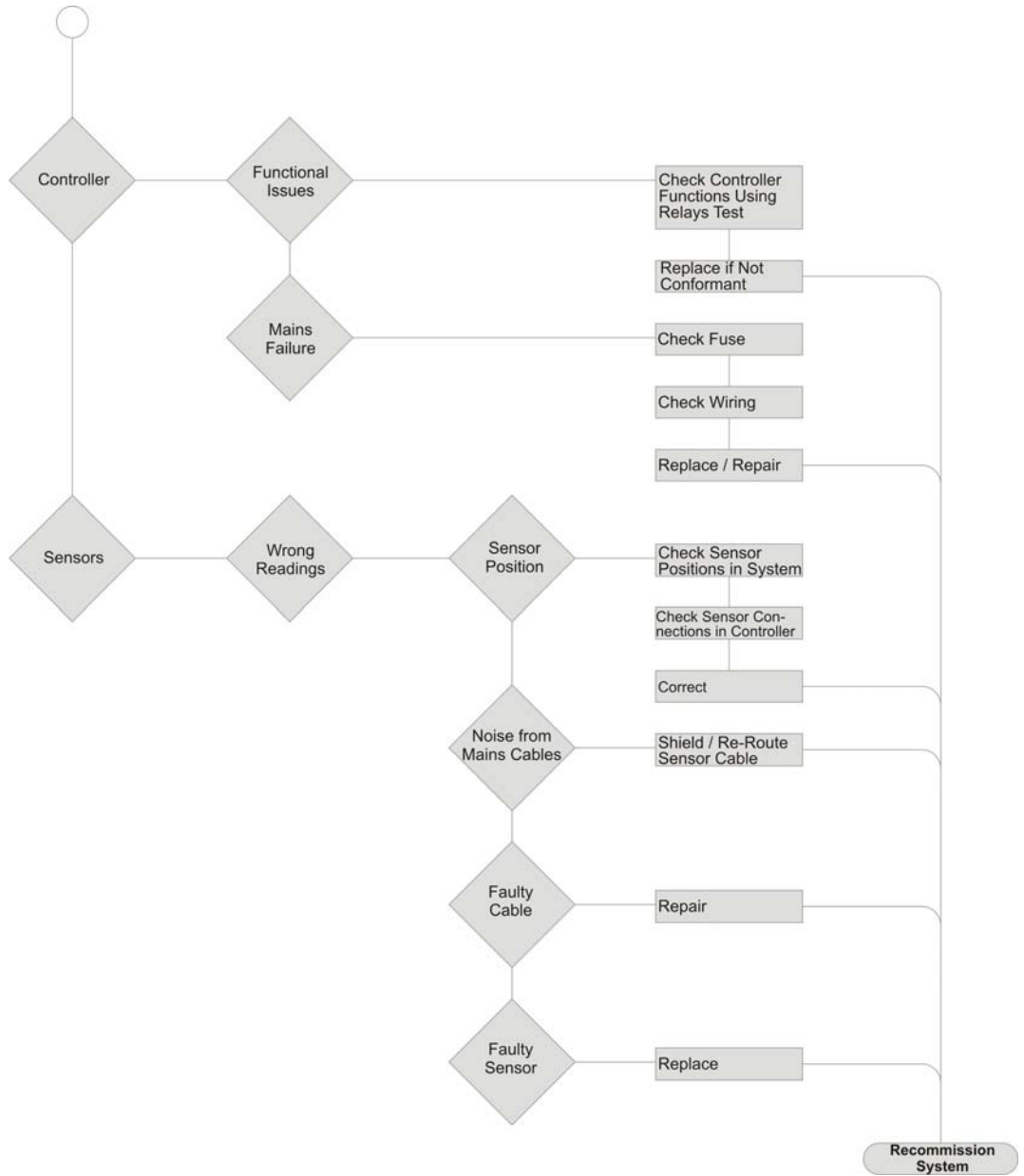

D

Troubleshooting

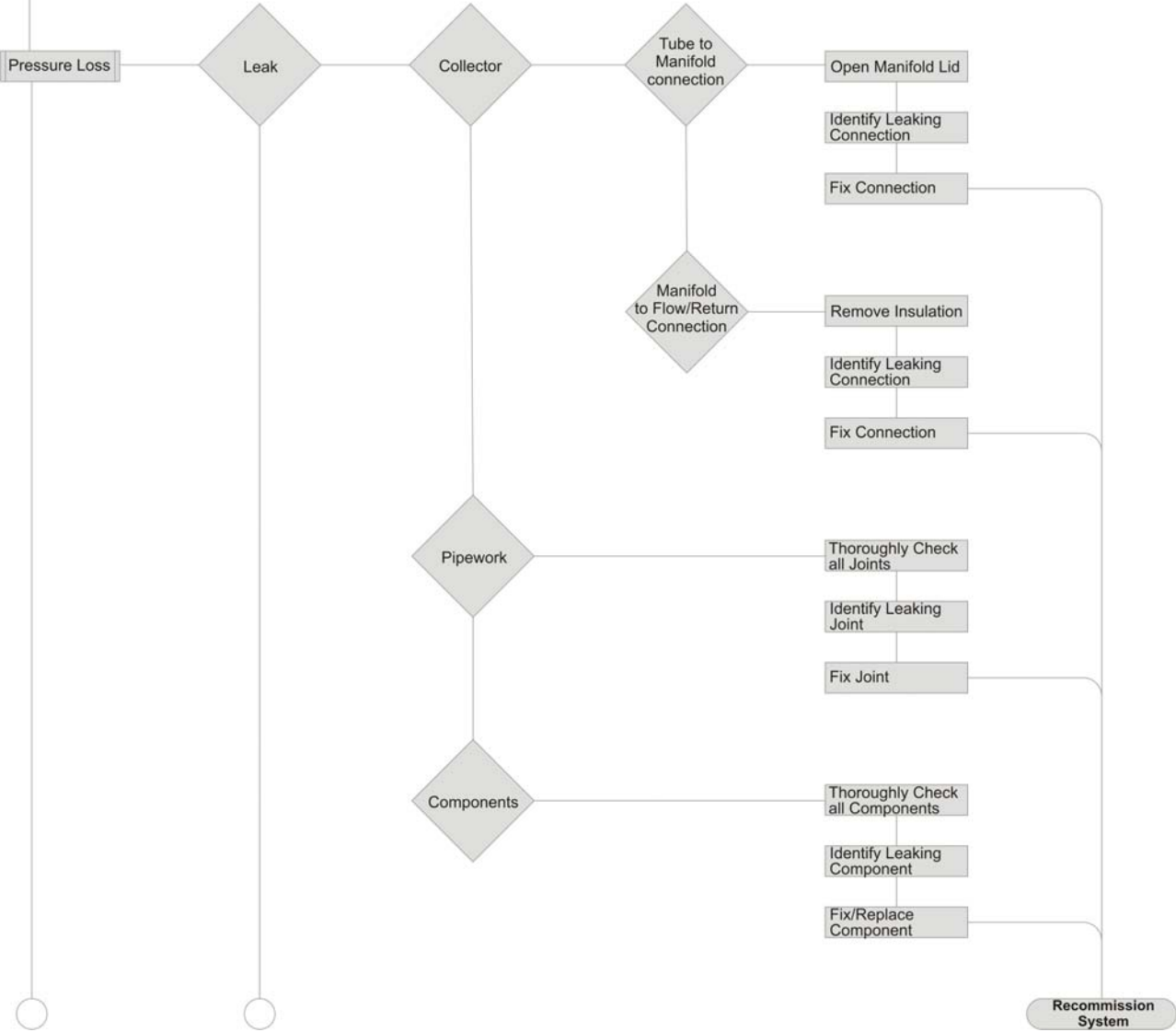

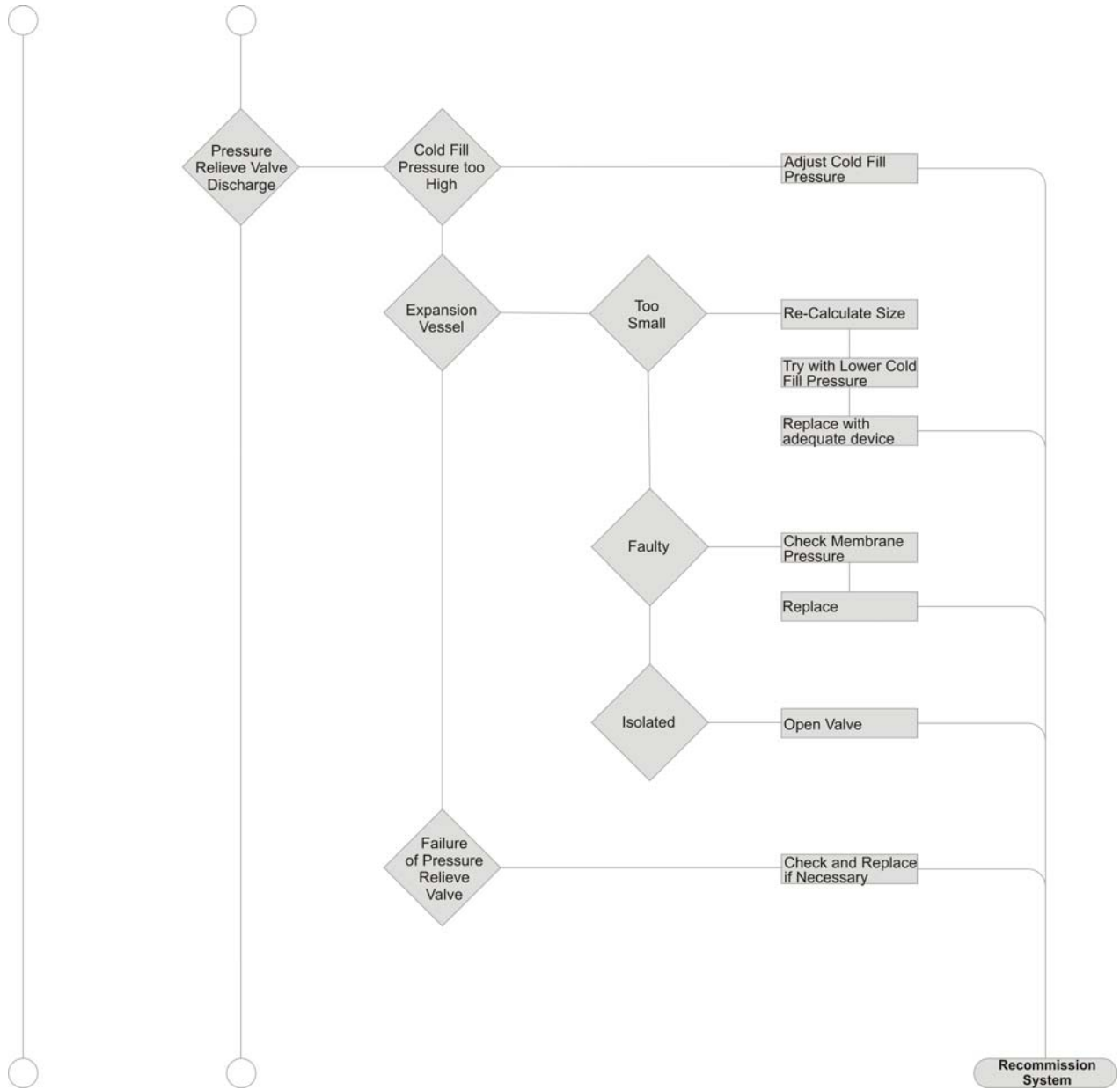

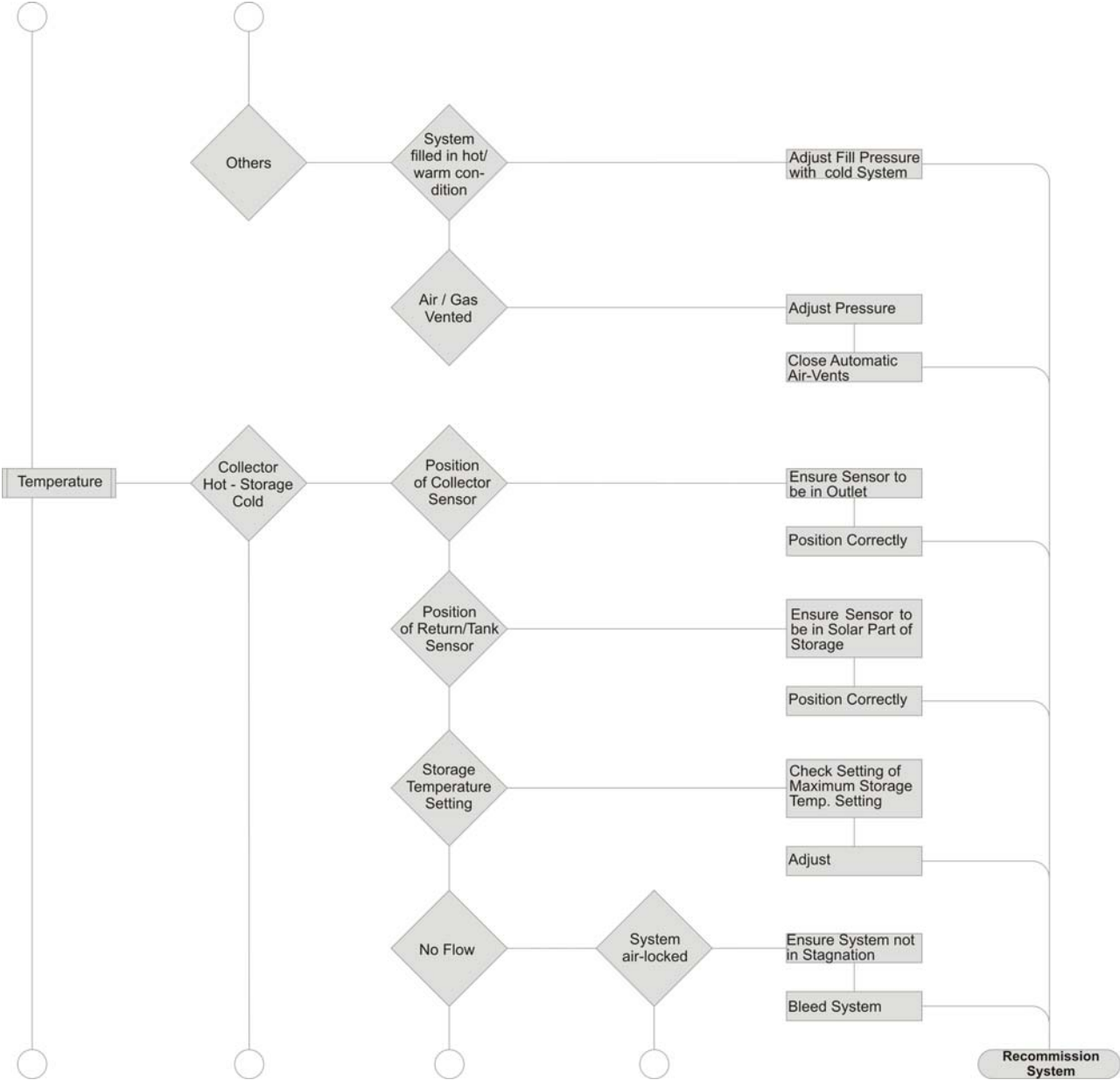

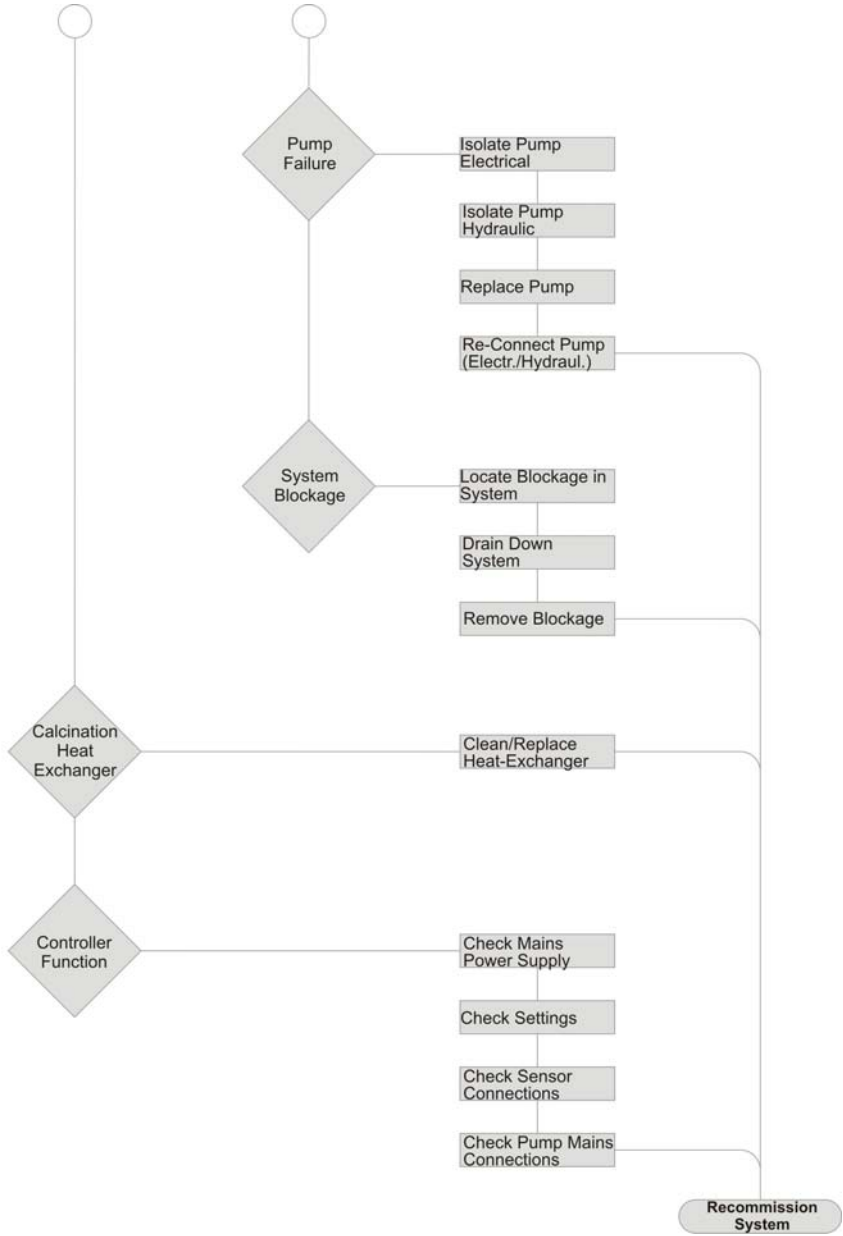

D

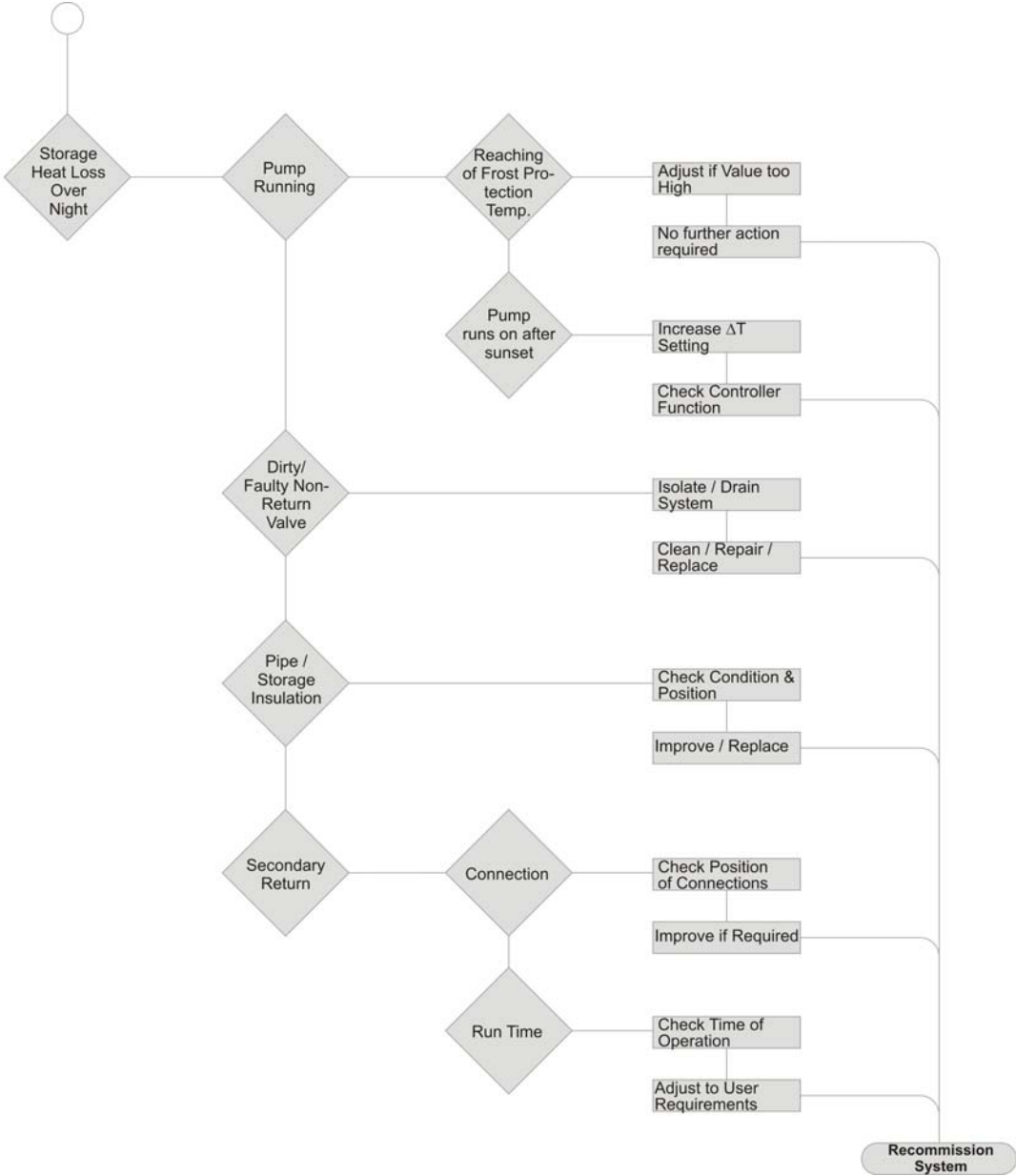

D

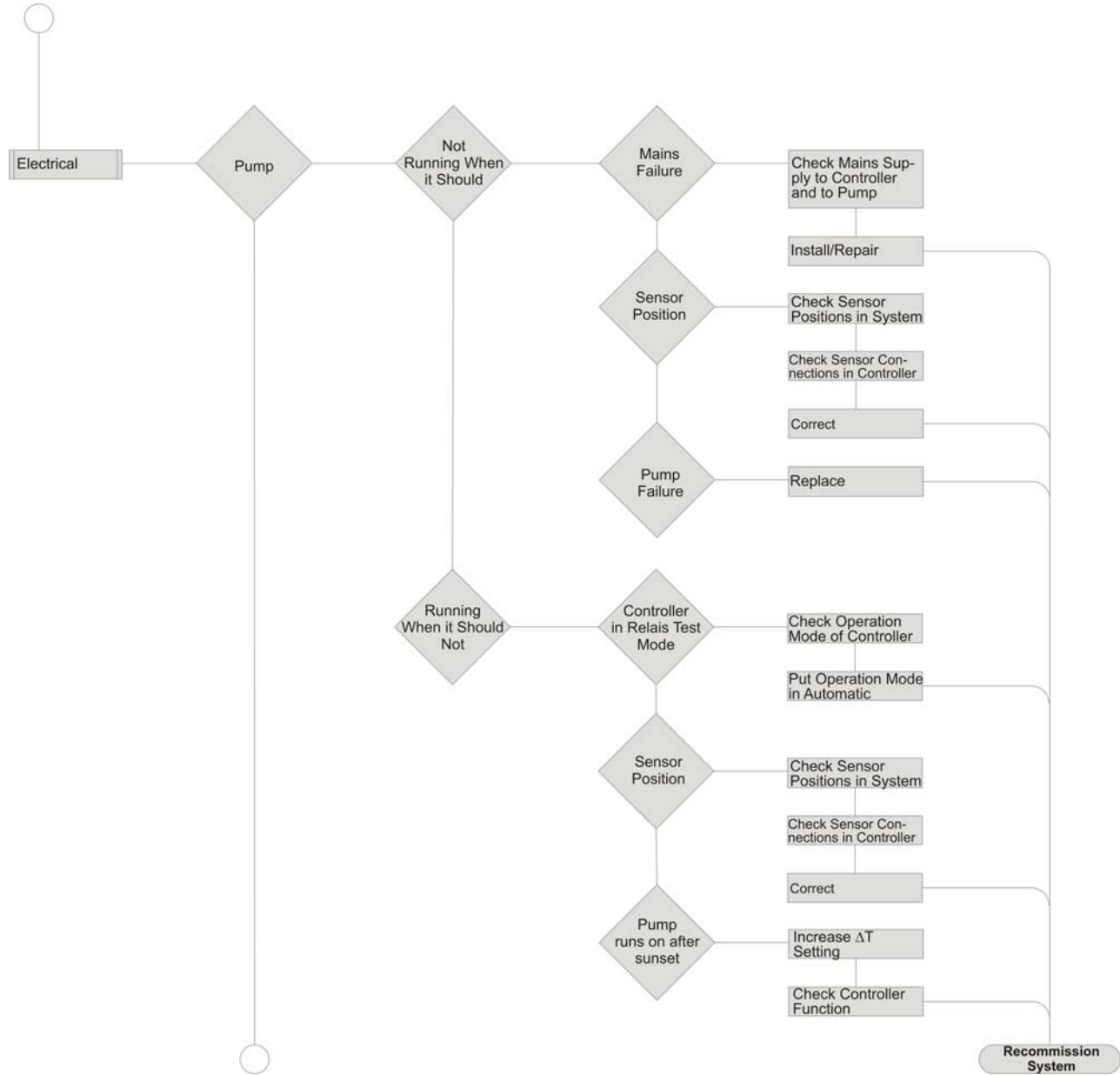

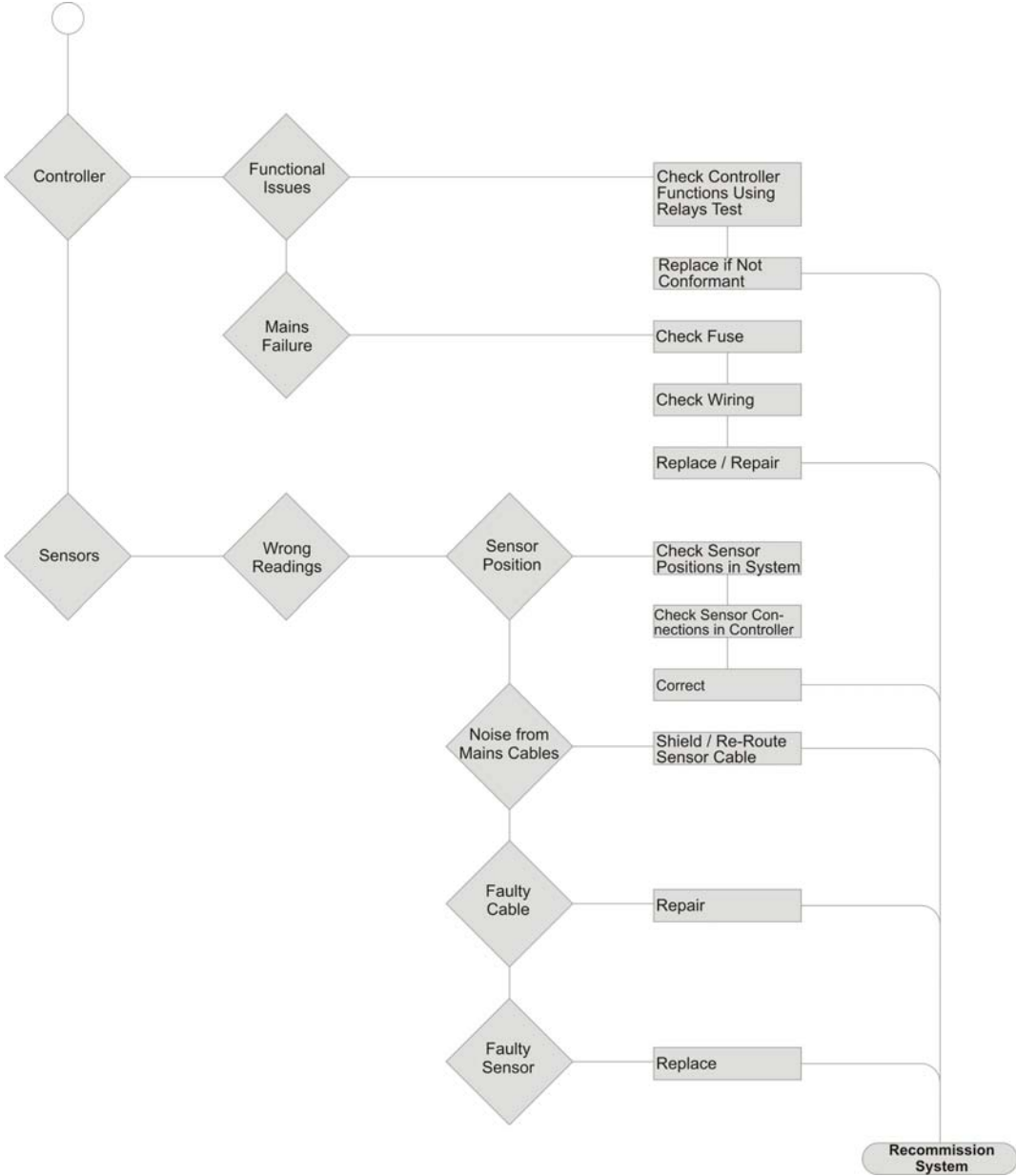

I

Troubleshooting

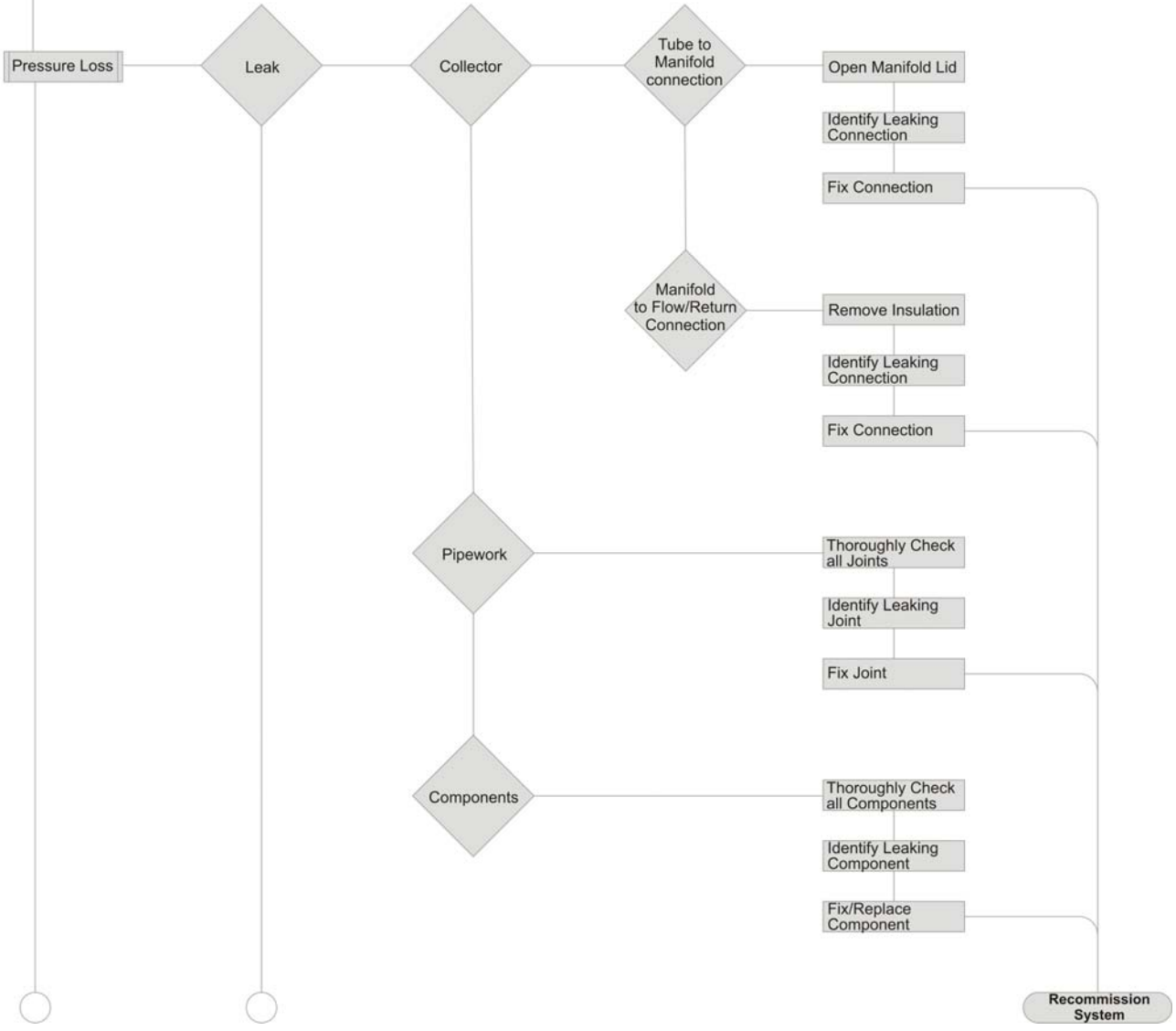

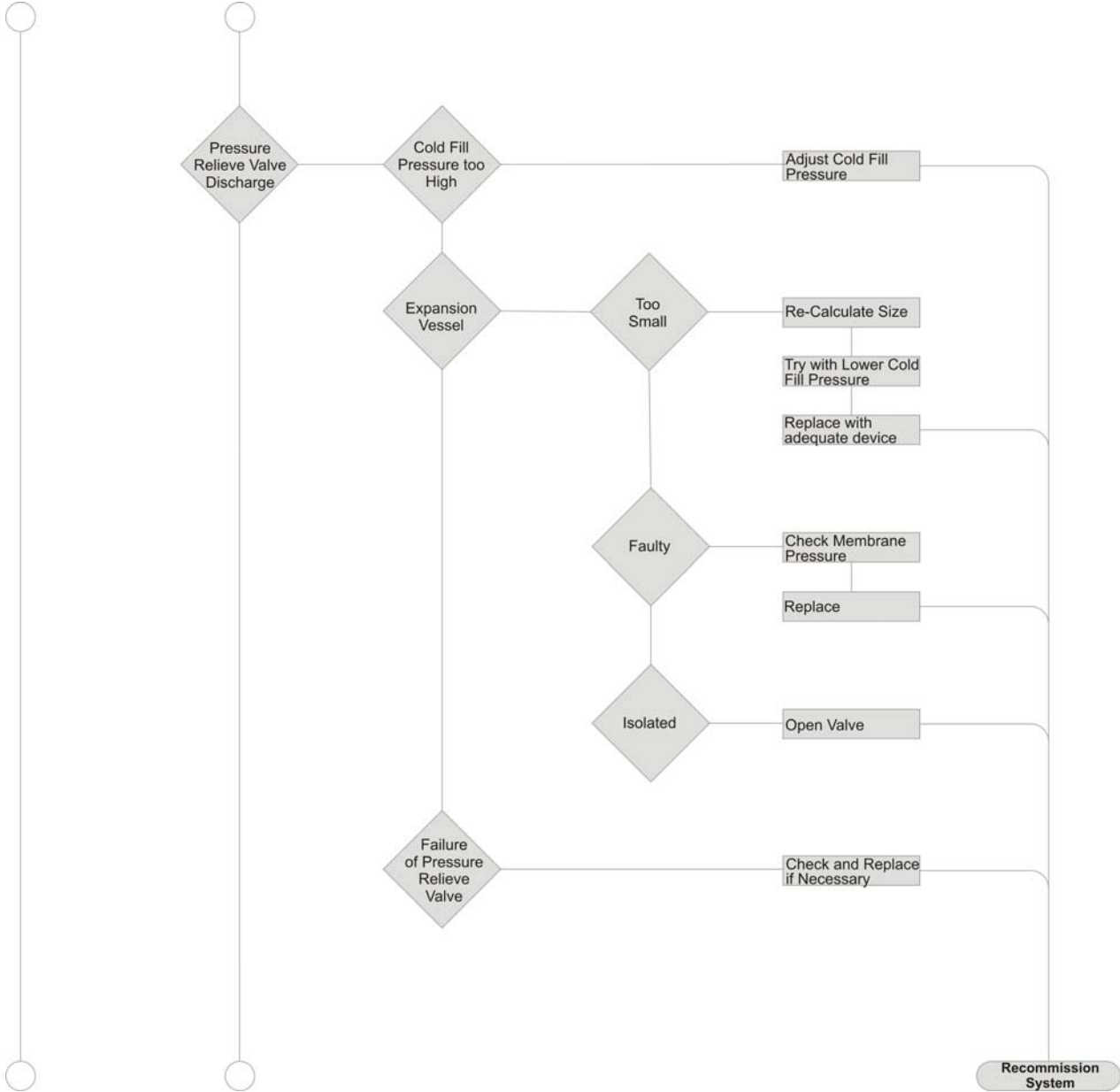

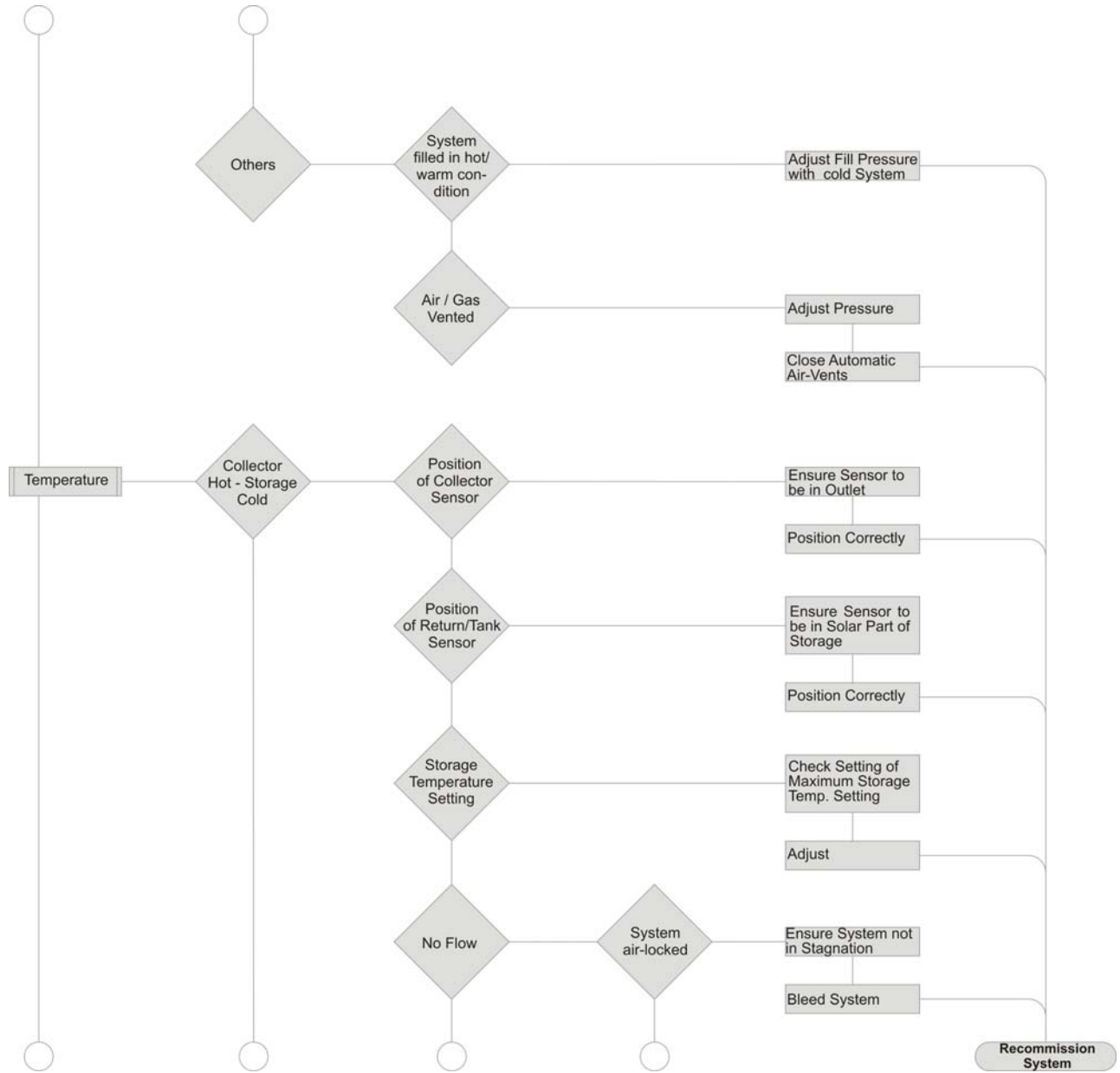

I

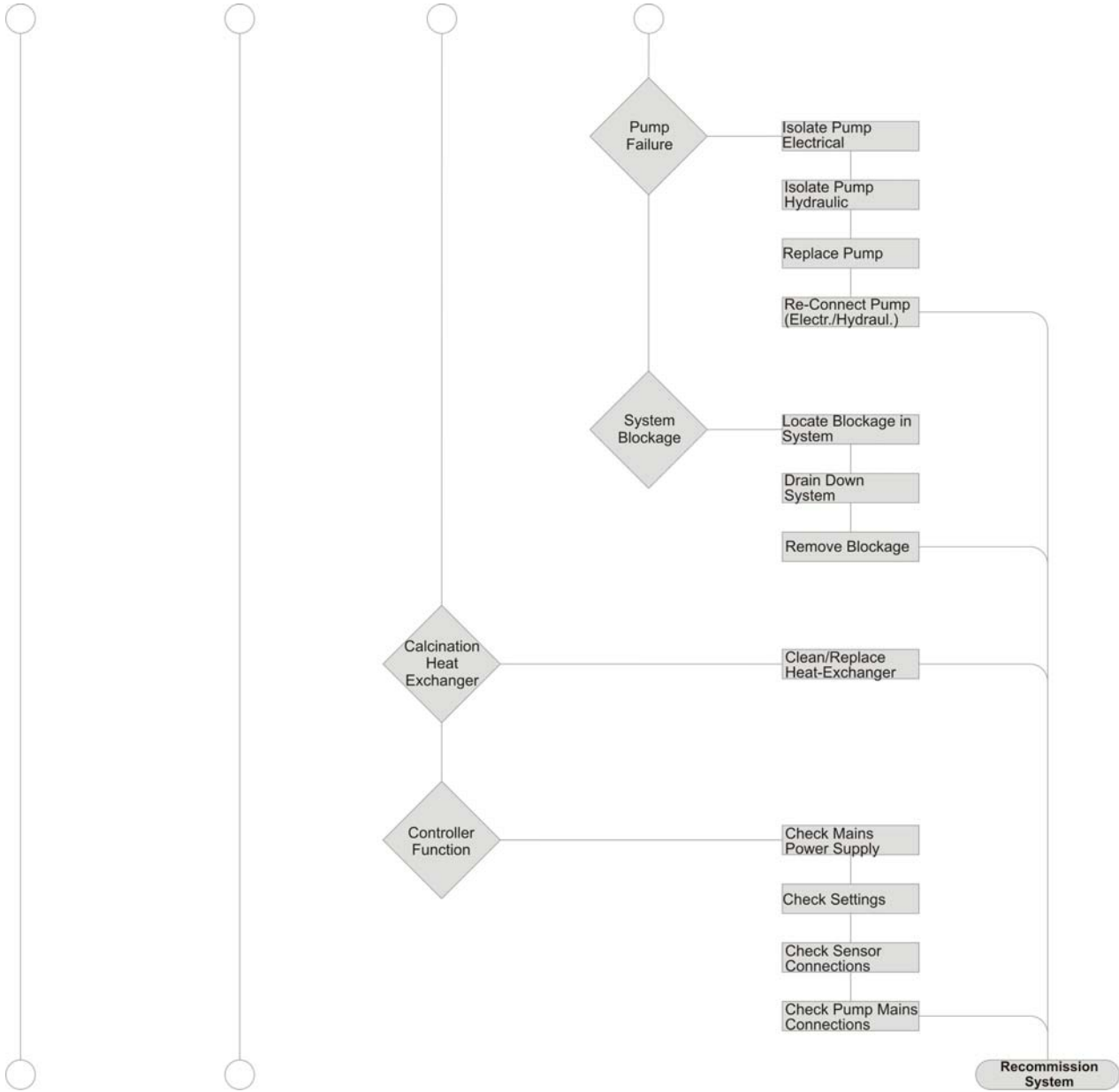

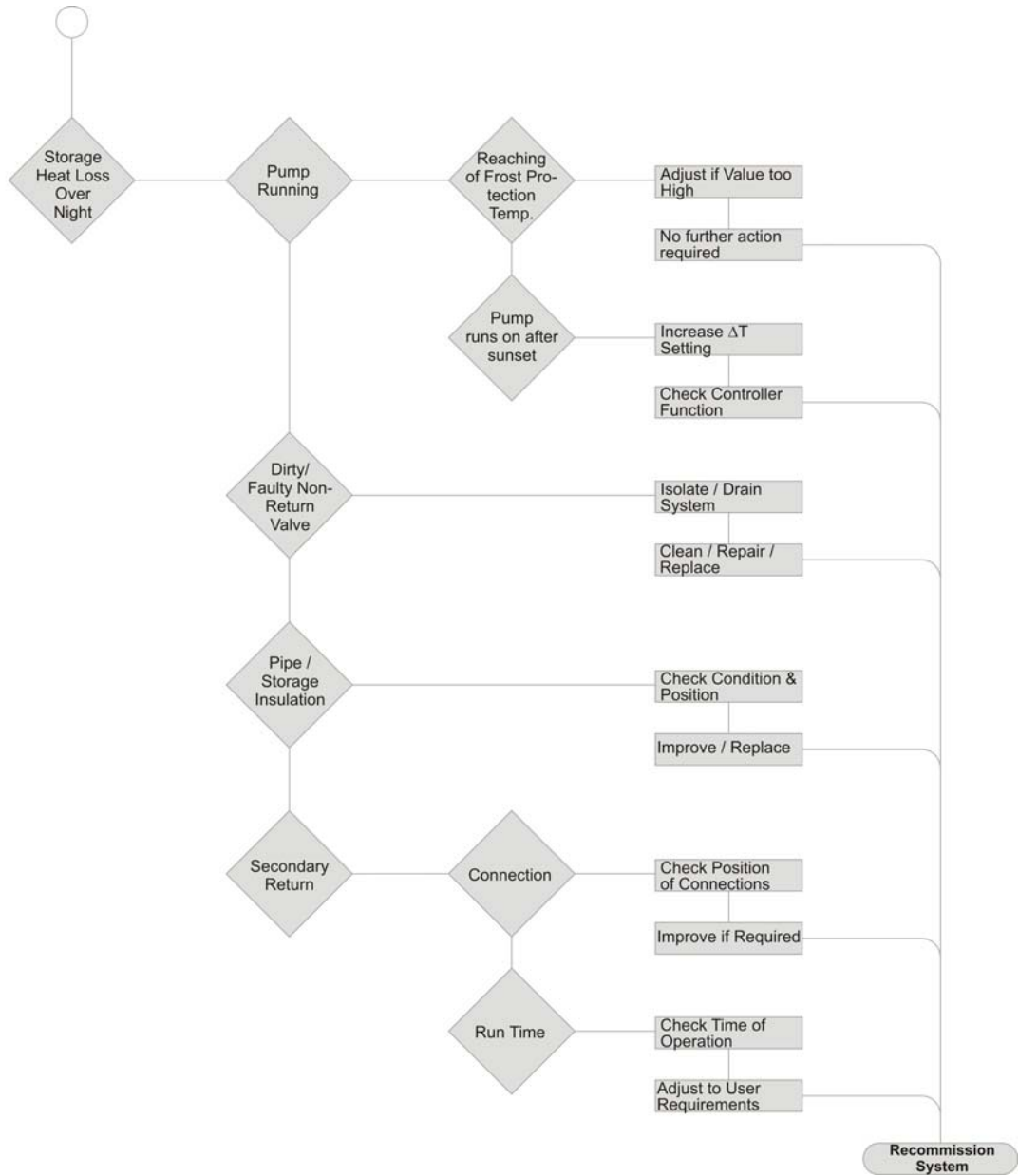

I

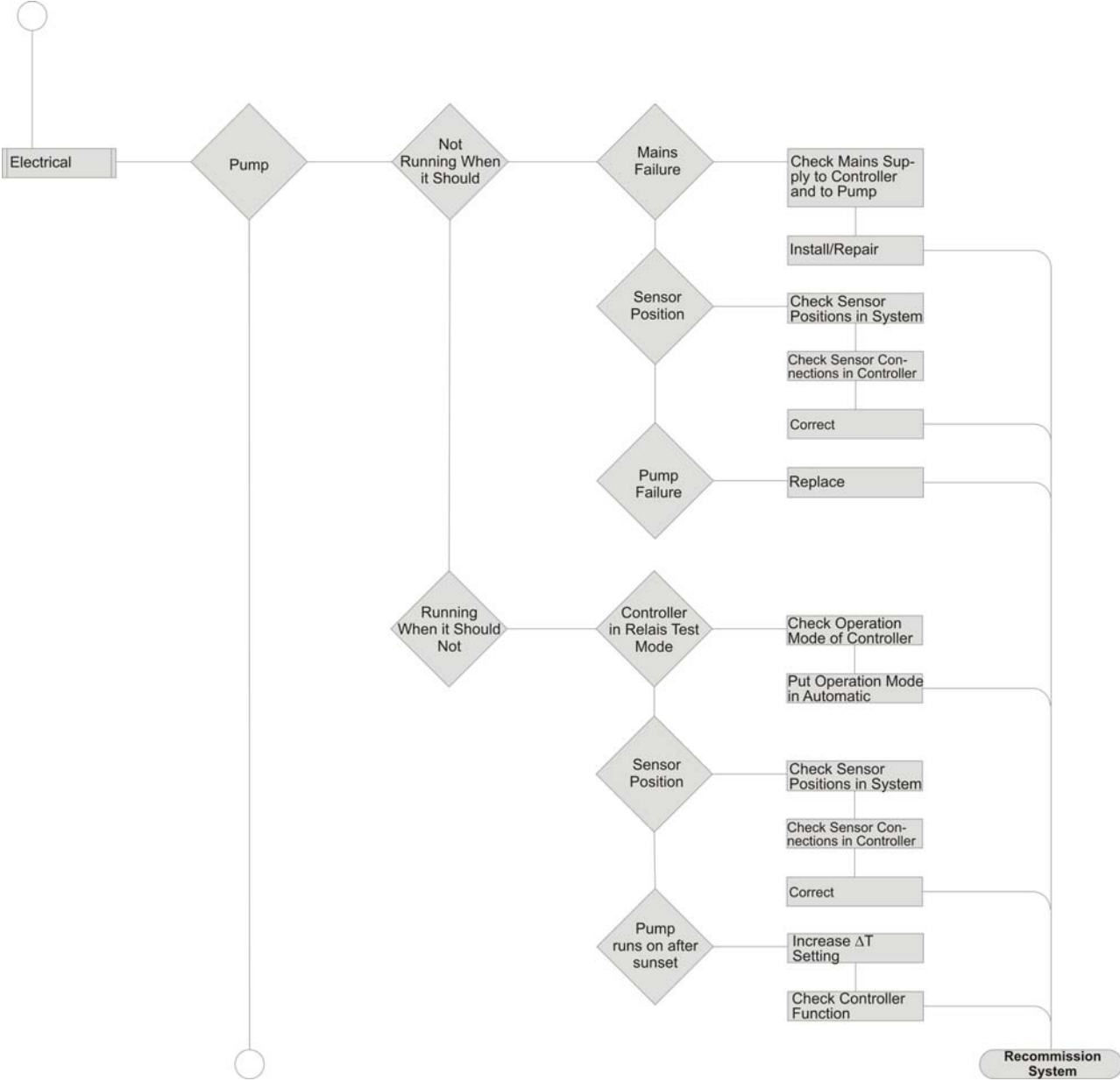

I

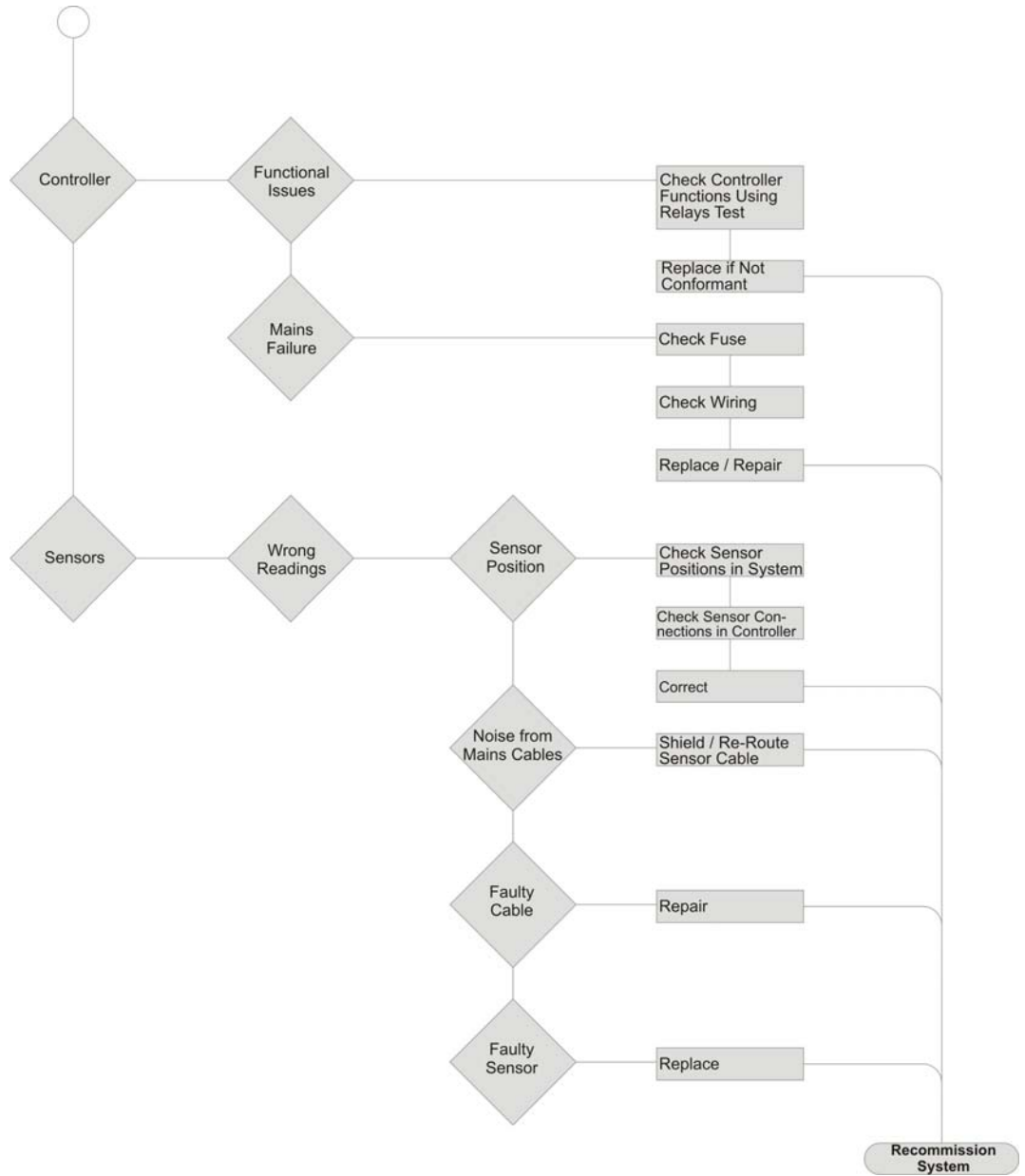

E

Troubleshooting

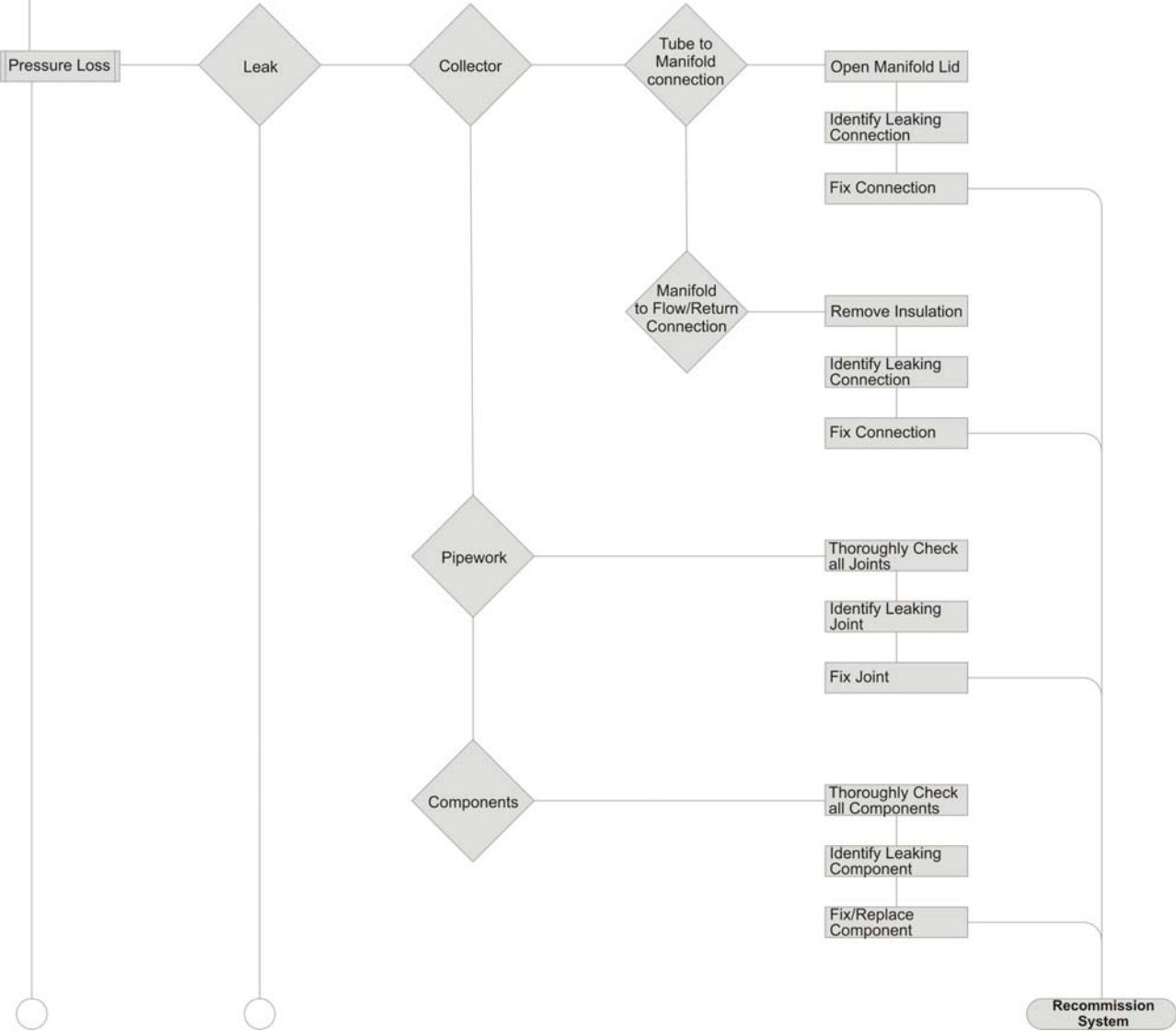

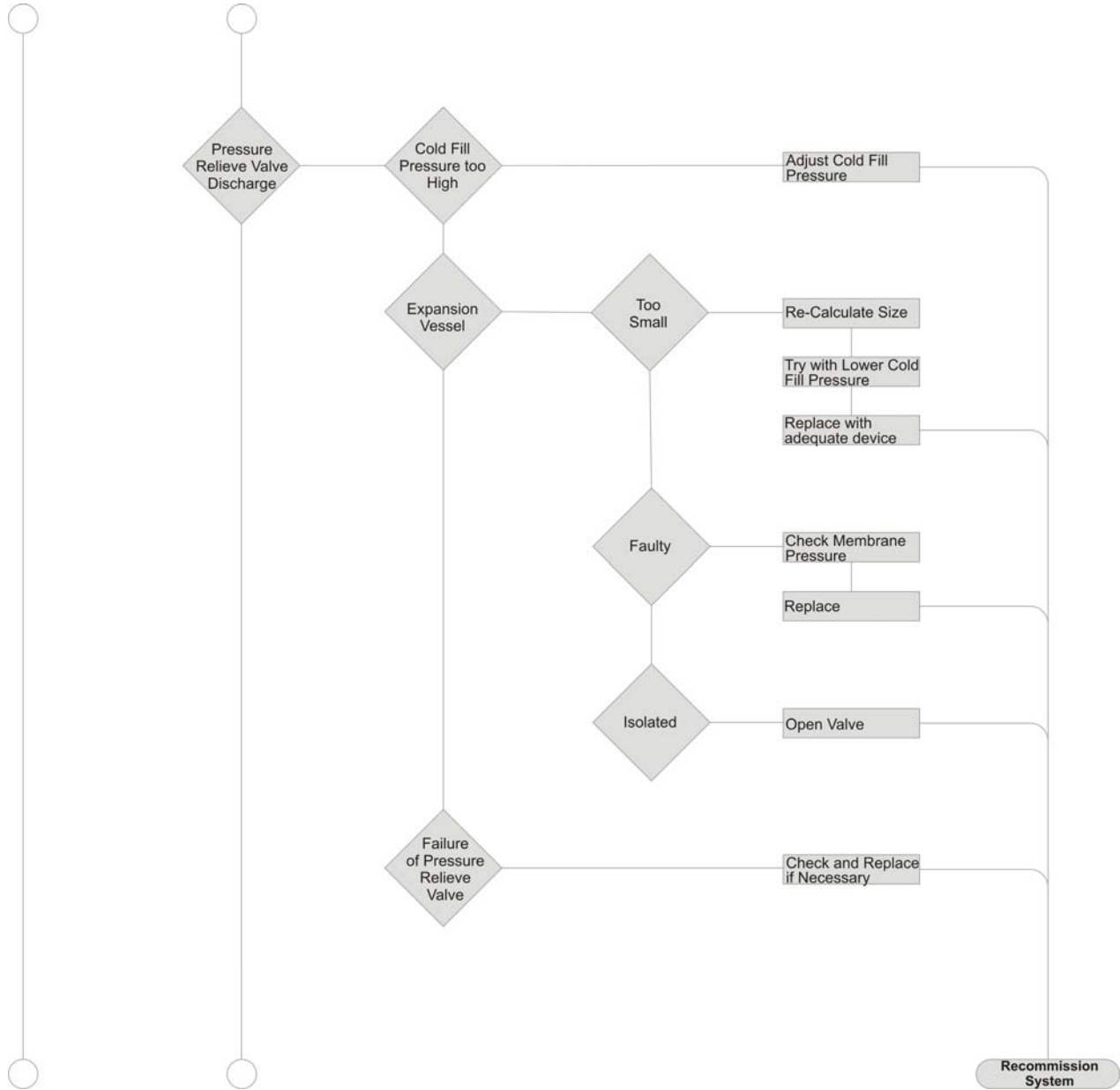

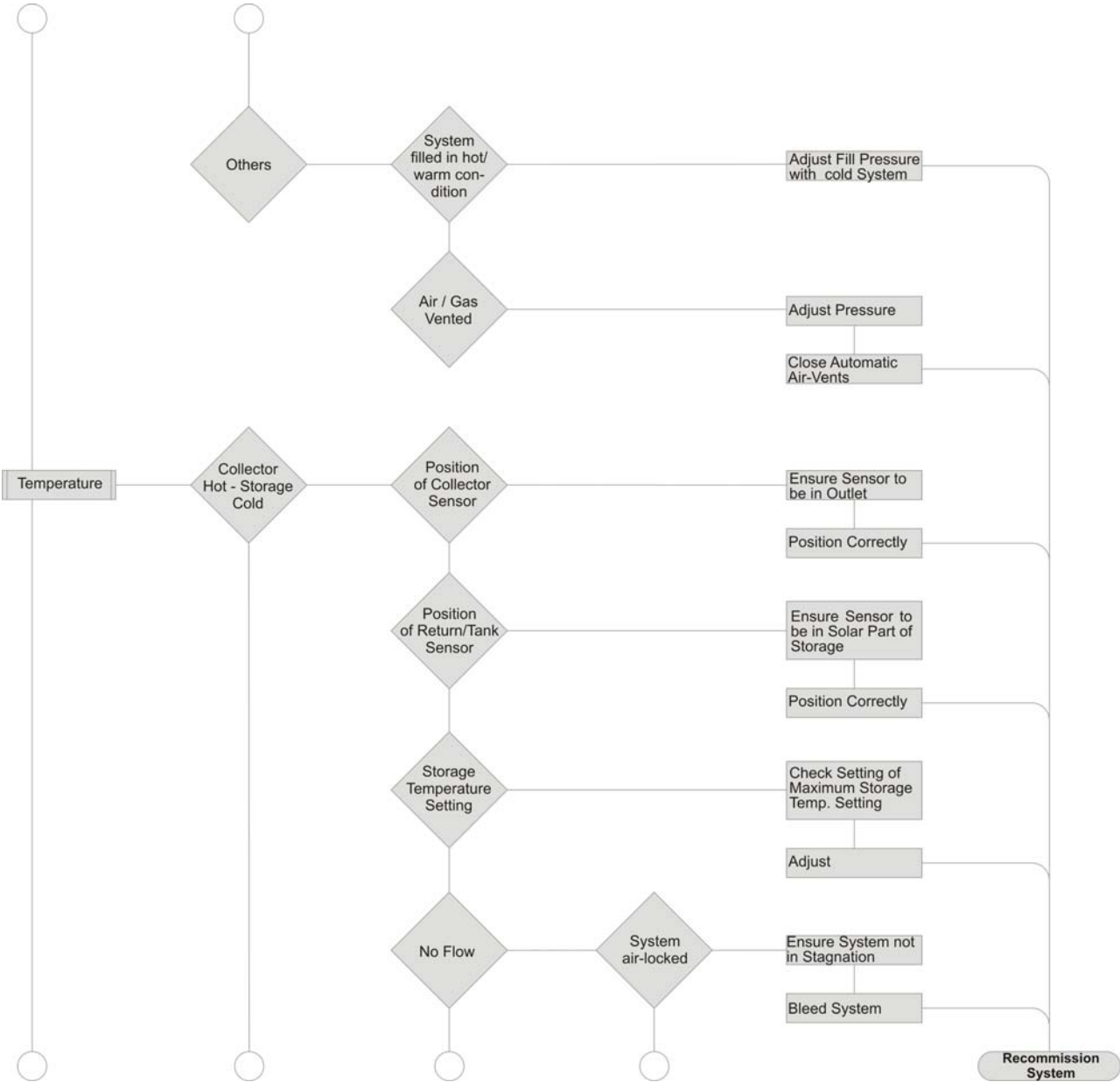

E

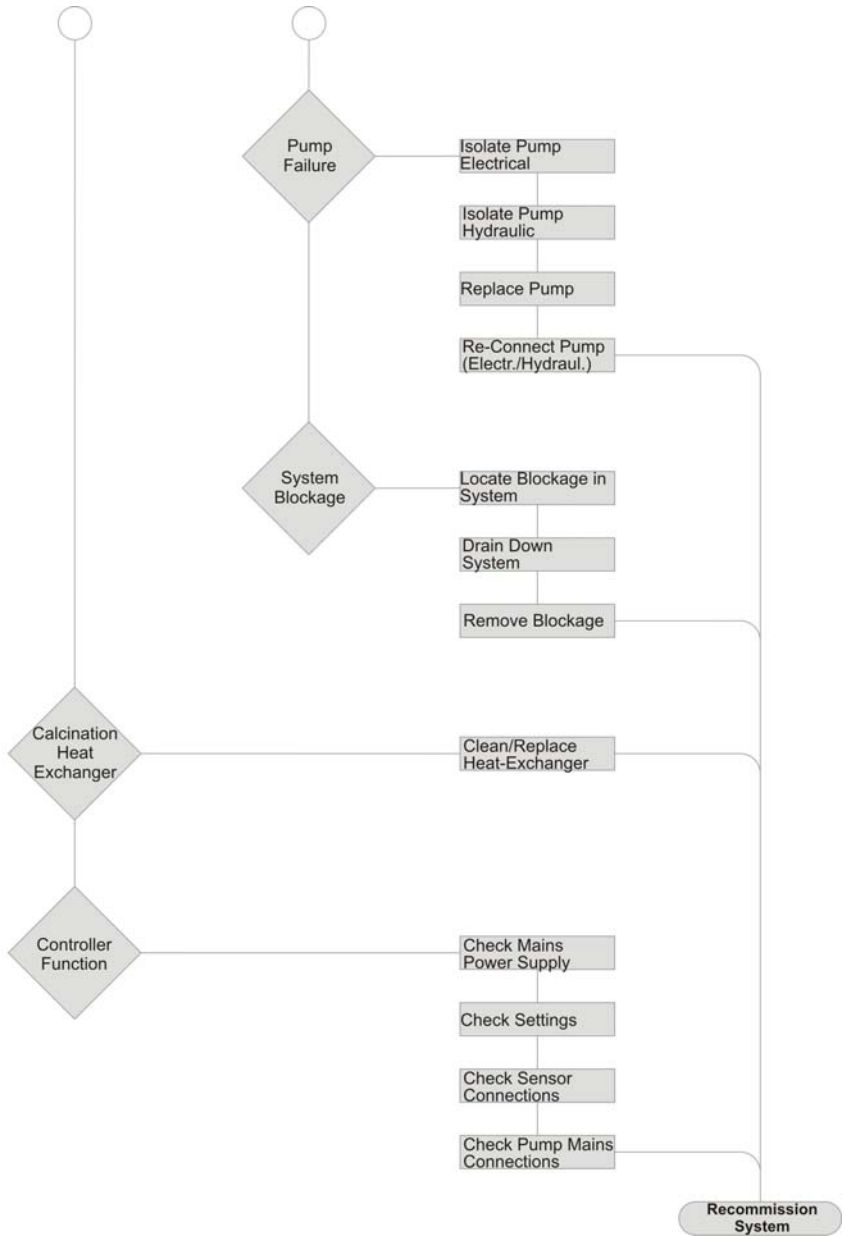

E

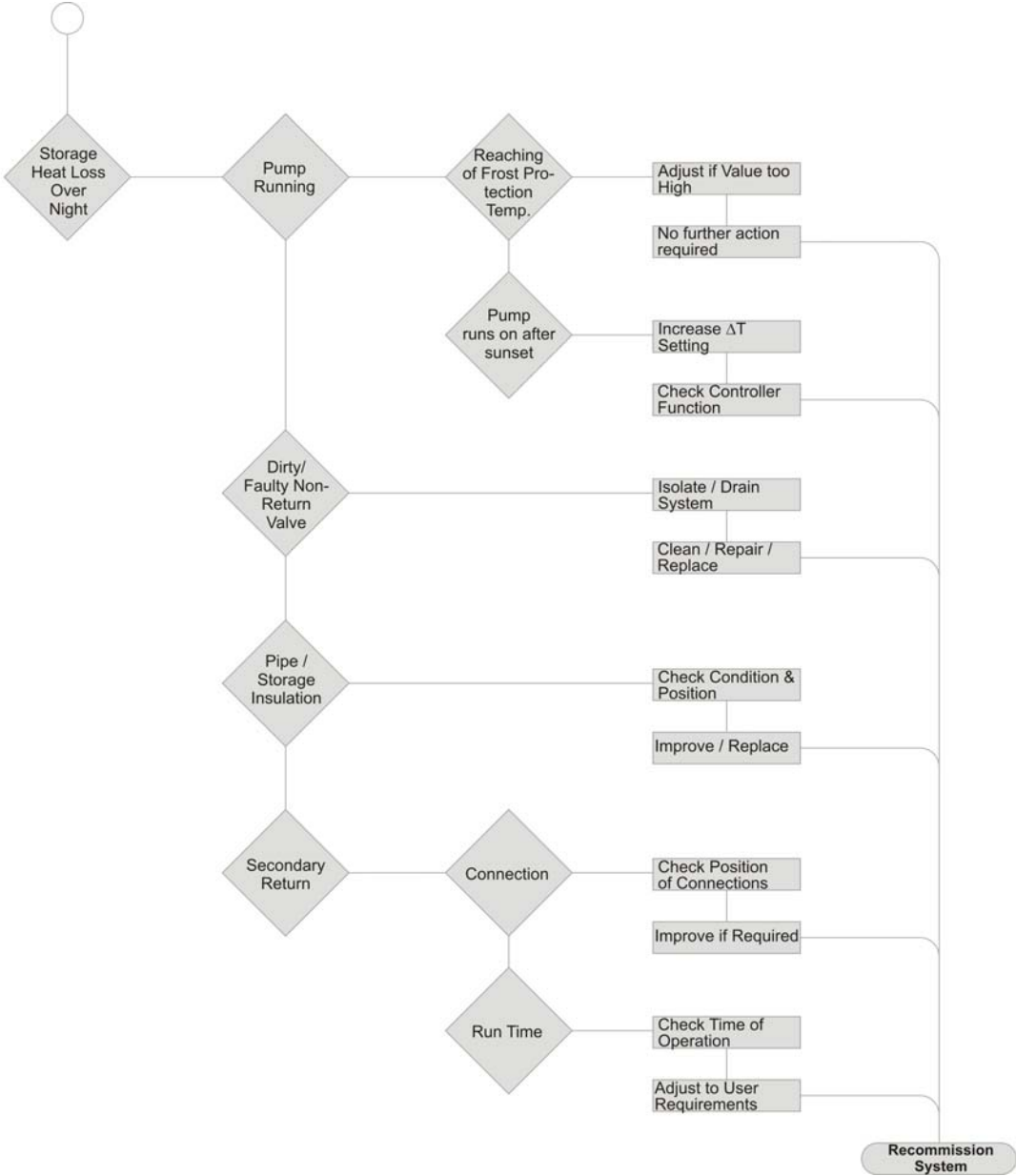

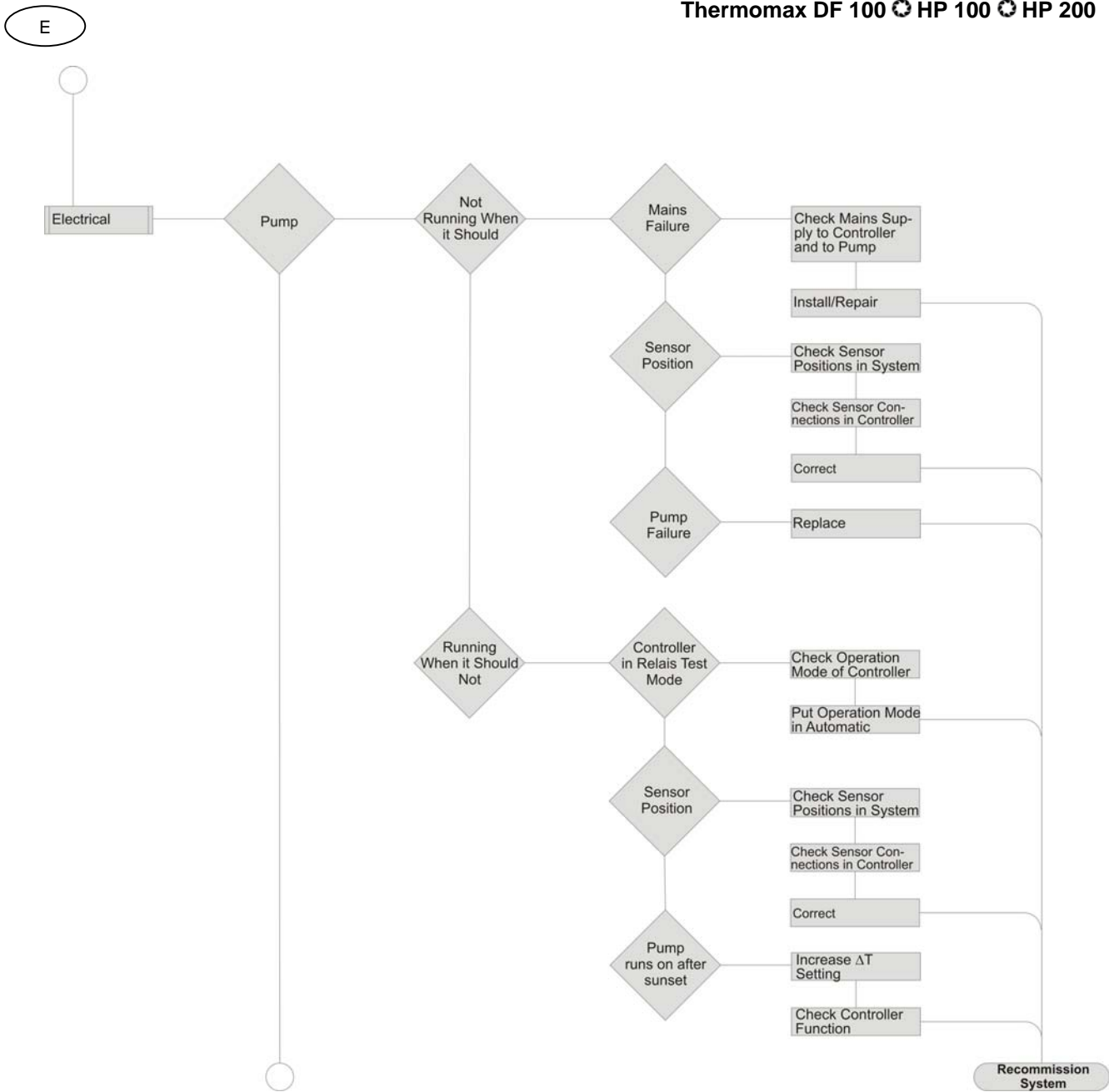

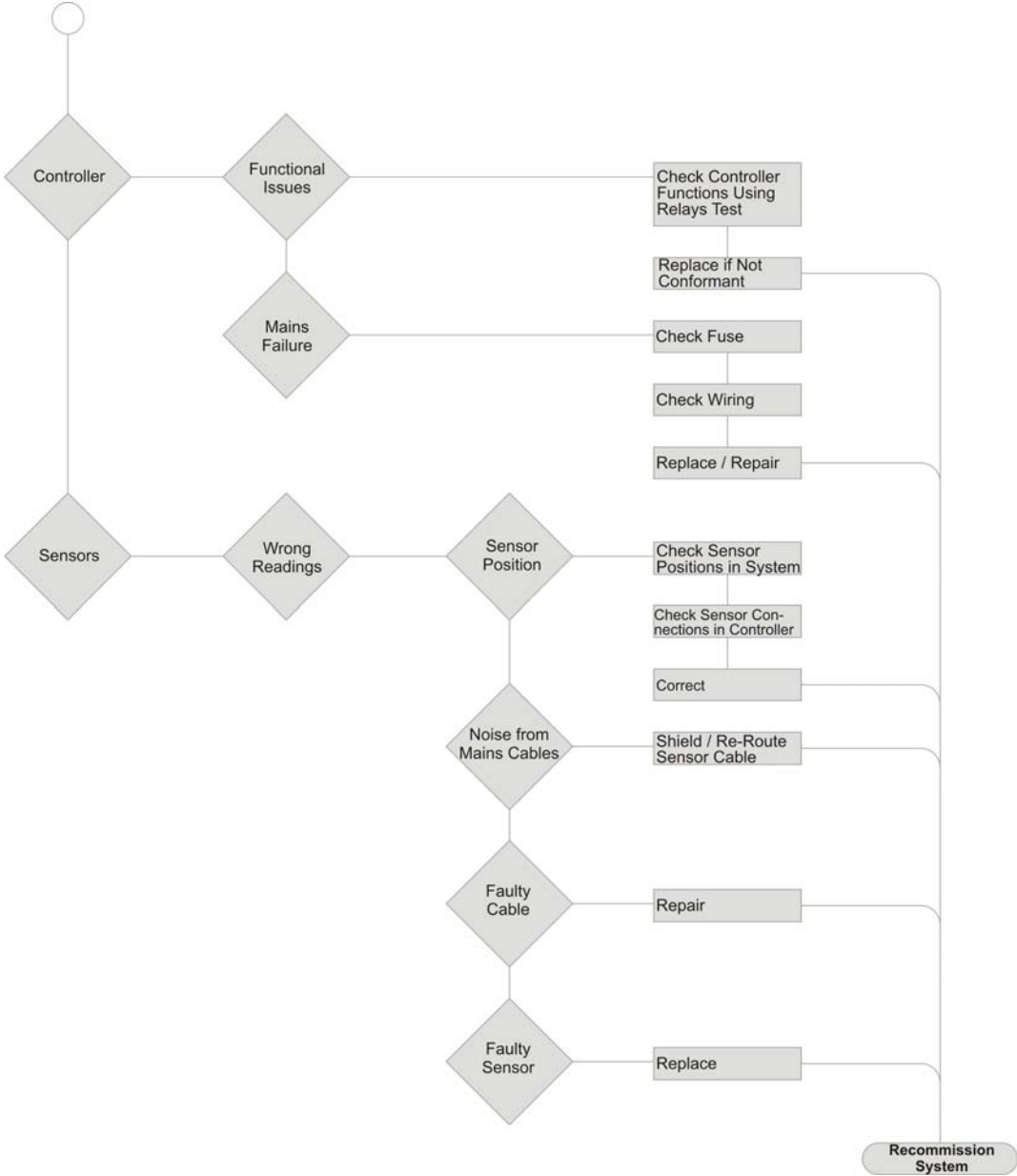

GB

## 5 Dismantling

- 5.1 Procedure
- 5.2 Recycling Details

F

## 5 Dismantling

- 5.1 Procedure
- 5.2 Recycling Details

D

## 5 Dismantling

- 5.1 Procedure
- 5.2 Recycling Details

I

## 5 Dismantling

- 5.1 Procedure
- 5.2 Recycling Details

E

## 5 Dismantling

- 5.1 Procedure
- 5.2 Recycling Details

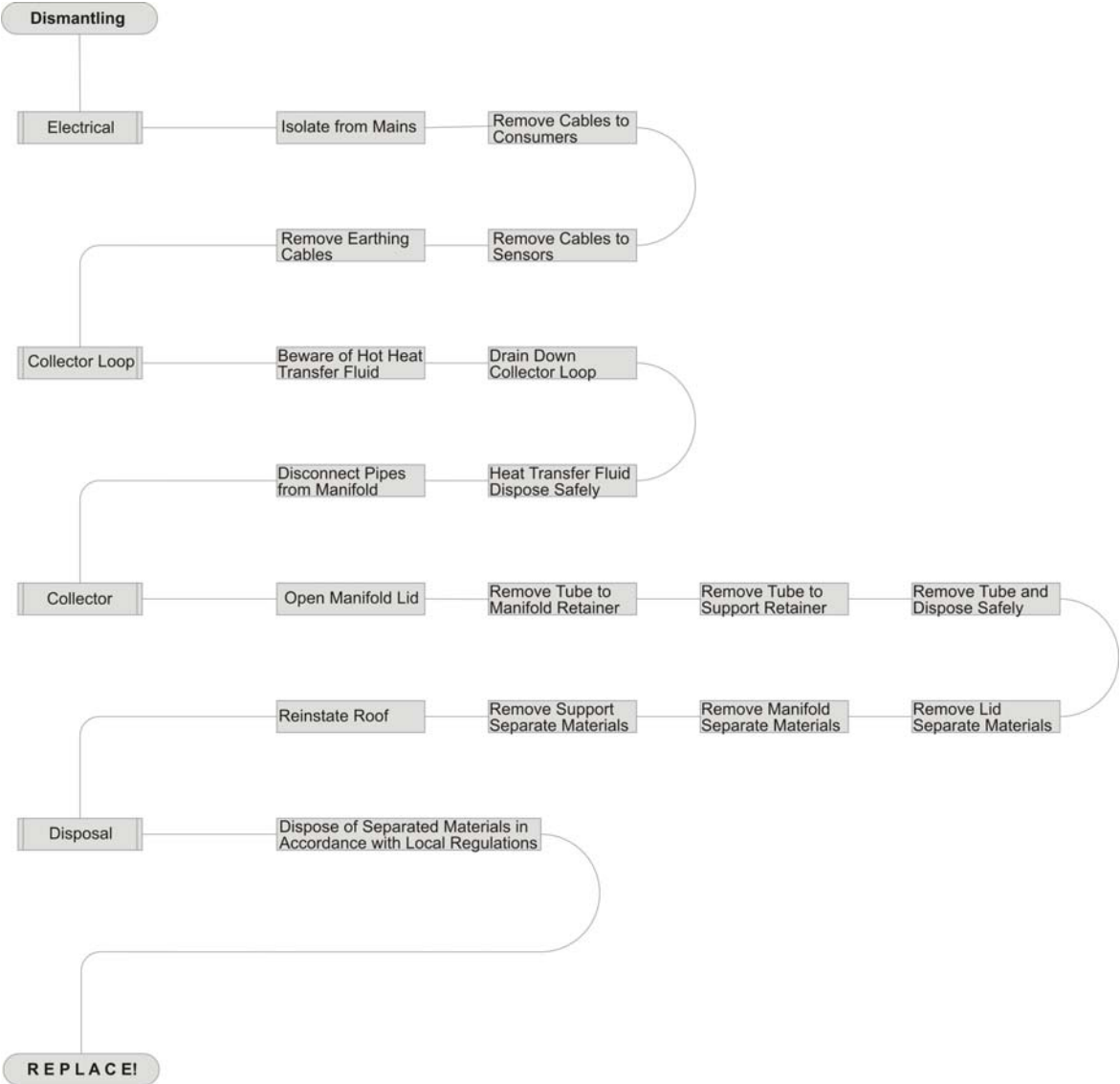

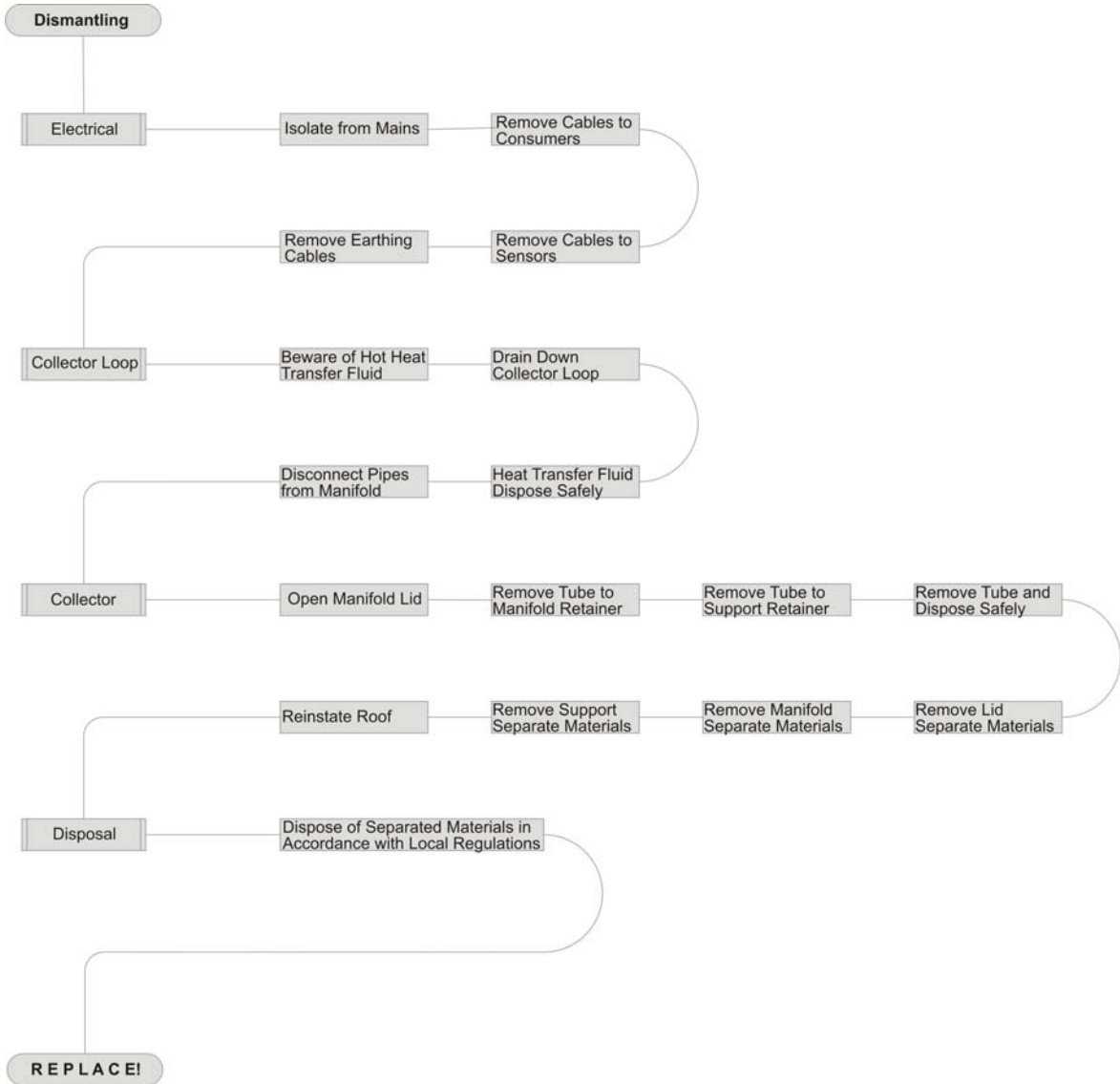

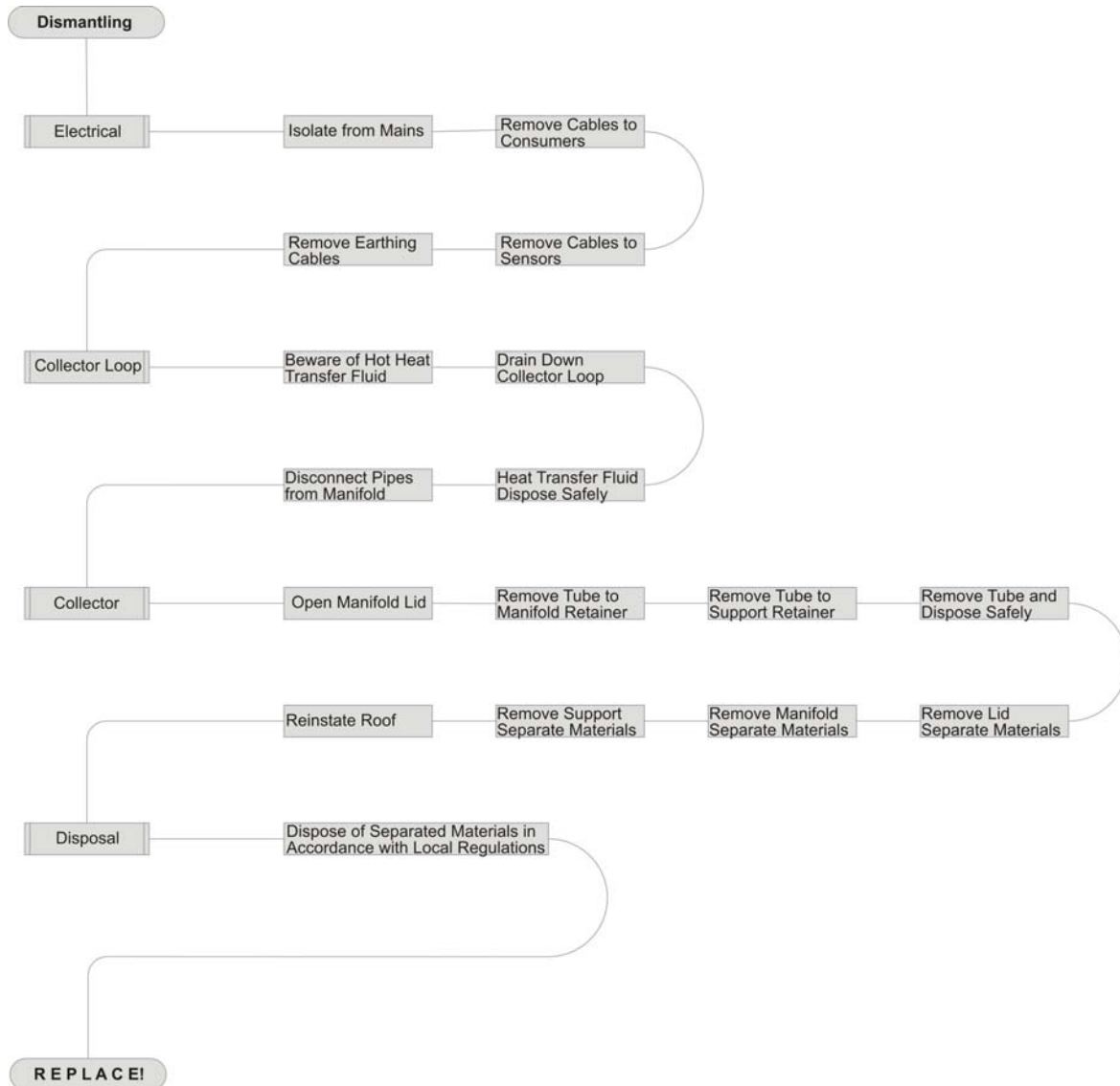

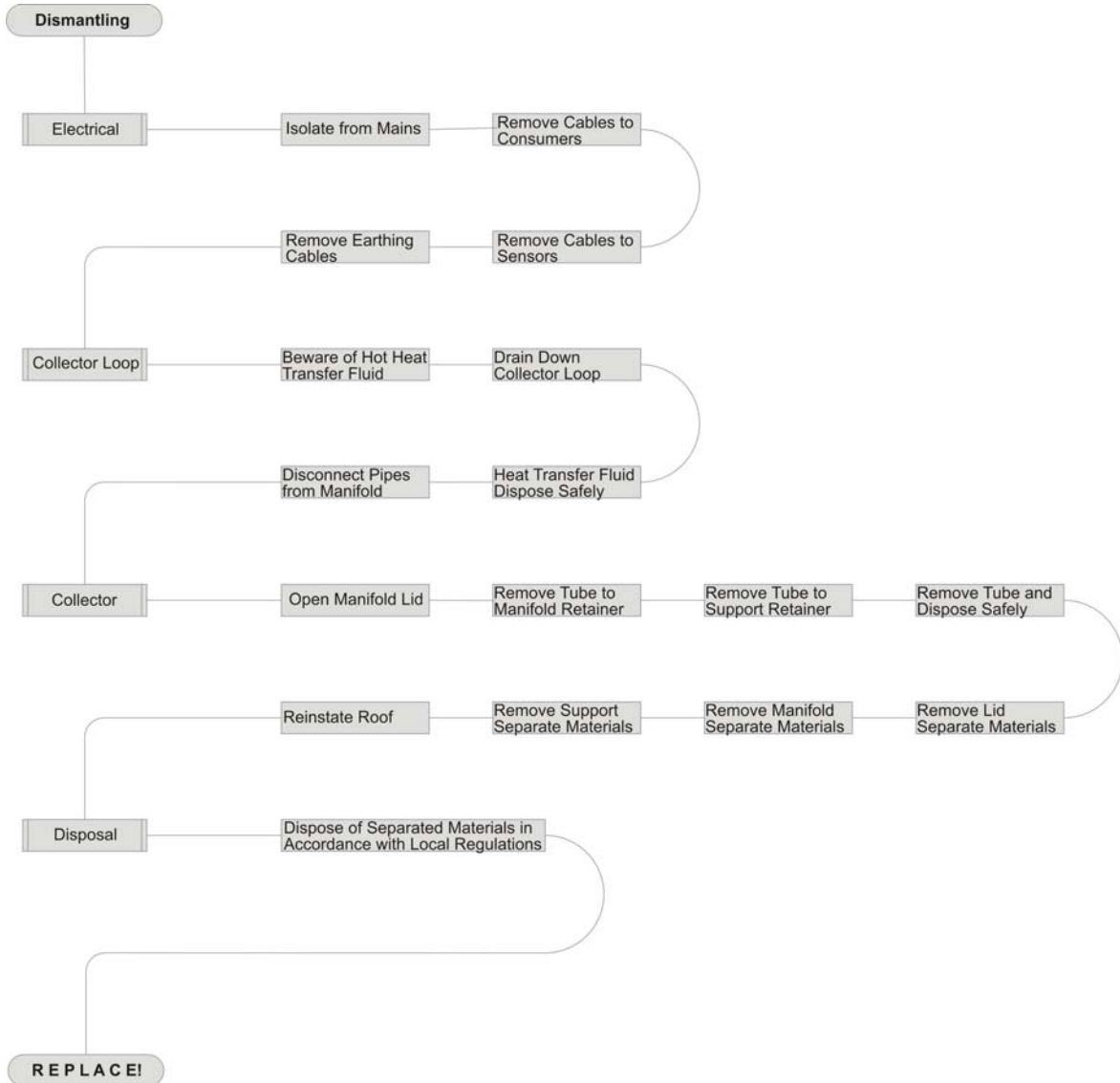

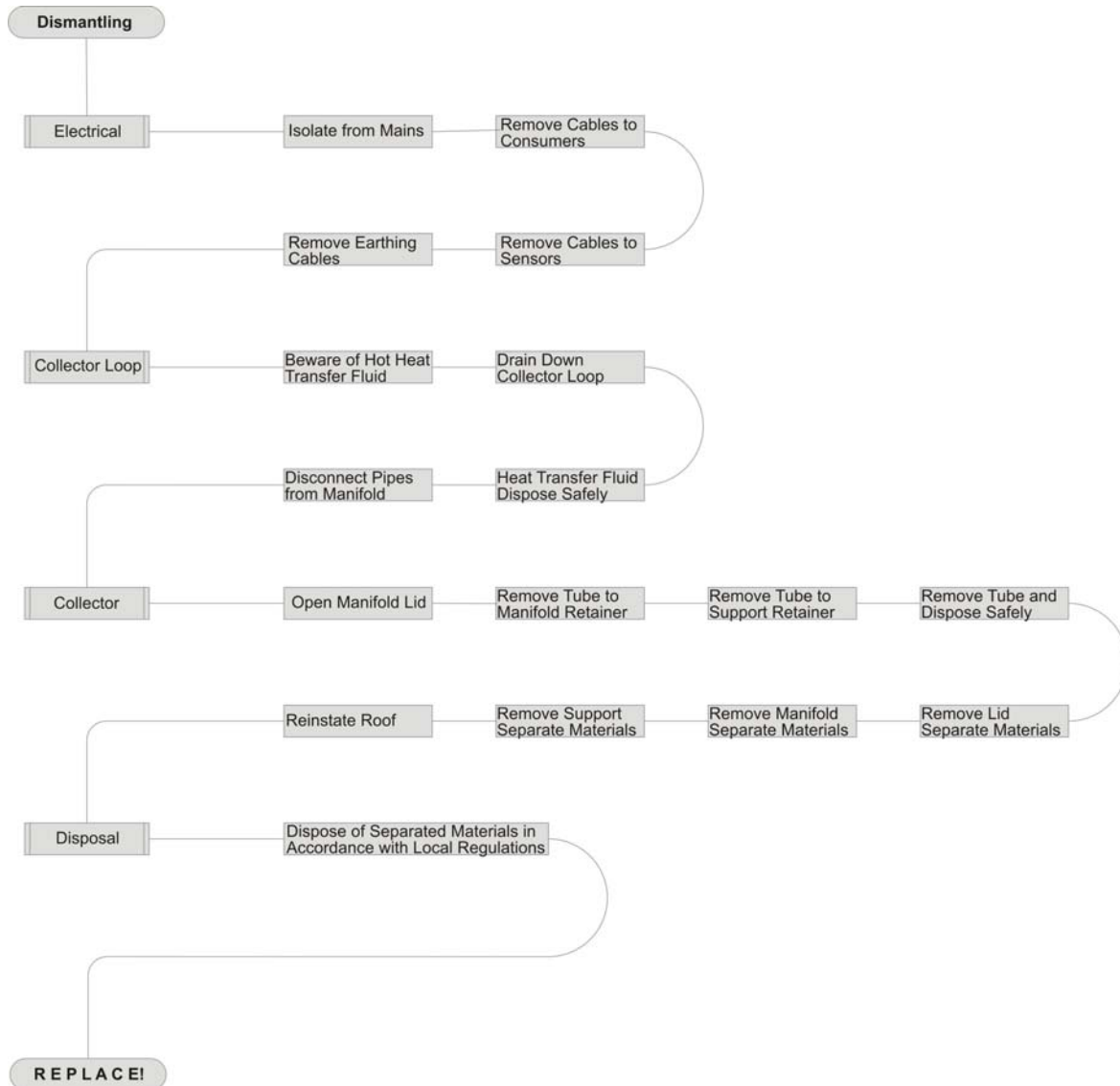

DF 100

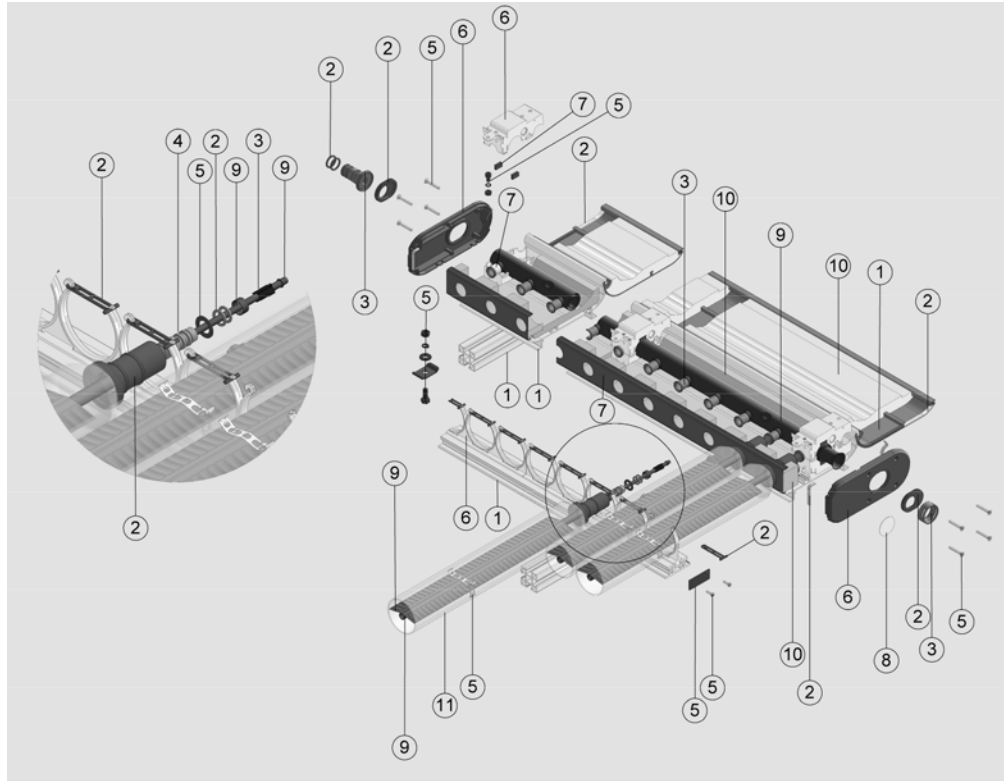

	<b>GB</b>	<b>F</b>	<b>D</b>	<b>I</b>	<b>E</b>
<b>1</b>	Aluminium	Aluminium	Aluminium	Aluminium	Aluminium
<b>2</b>	EPDM	EPDM	EPDM	EPDM	EPDM
<b>3</b>	Brass	Brass	Messing	Brass	Brass
<b>4</b>	Bronze	Bronze	Bronze	Bronze	Bronze
<b>5</b>	Stainless Steel	Stainless Steel	Edelstahl	Stainless Steel	Stainless Steel
<b>6</b>	PA66 30% GF	PA66 30% GF	PA66 30% GF	PA66 30% GF	PA66 30% GF
<b>7</b>	Silicon	Silicon	Silicon	Silicon	Silicon
<b>8</b>	Vinyl	Vinyl	Vinyl	Vinyl	Vinyl
<b>9</b>	Copper	Copper	Kupfer	Copper	Copper
<b>10</b>	Melamine	Melamine	Melaminschaum	Melamine	Melamine
<b>11</b>	Glass	Glass	Glas	Glass	Glass

HP 100

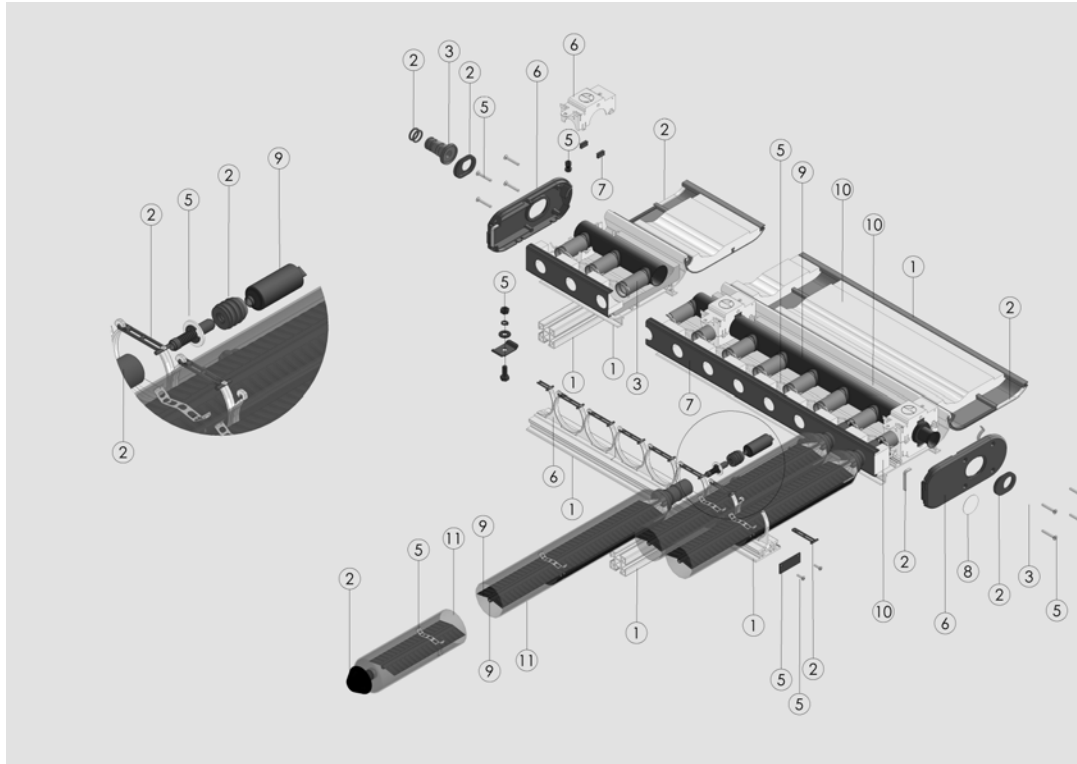

	<b>GB</b>	<b>F</b>	<b>D</b>	<b>I</b>	<b>E</b>
<b>1</b>	Aluminium	Aluminium	Aluminium	Aluminium	Aluminium
<b>2</b>	EPDM	EPDM	EPDM	EPDM	EPDM
<b>3</b>	Brass	Brass	Messing	Brass	Brass
<b>4</b>	Bronze	Bronze	Bronze	Bronze	Bronze
<b>5</b>	Stainless Steel	Stainless Steel	Edelstahl	Stainless Steel	Stainless Steel
<b>6</b>	PA66 30% GF	PA66 30% GF	PA66 30% GF	PA66 30% GF	PA66 30% GF
<b>7</b>	Silicon	Silicon	Silicon	Silicon	Silicon
<b>8</b>	Vinyl	Vinyl	Vinyl	Vinyl	Vinyl
<b>9</b>	Copper	Copper	Kupfer	Copper	Copper
<b>10</b>	Melamine	Melamine	Melaminschaum	Melamine	Melamine
<b>11</b>	Glass	Glass	Glas	Glass	Glass

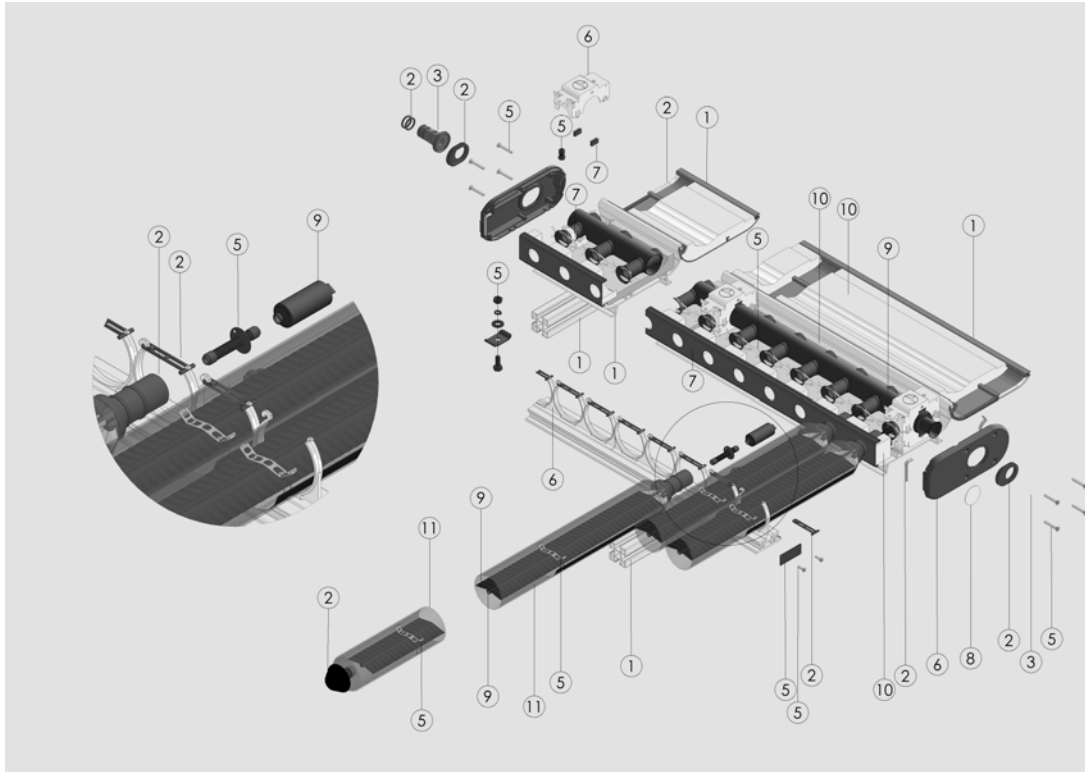

	<b>GB</b>	<b>F</b>	<b>D</b>	<b>I</b>	<b>E</b>
<b>1</b>	Aluminium	Aluminium	Aluminium	Aluminium	Aluminium
<b>2</b>	EPDM	EPDM	EPDM	EPDM	EPDM
<b>3</b>	Brass	Brass	Messing	Brass	Brass
<b>4</b>	Bronze	Bronze	Bronze	Bronze	Bronze
<b>5</b>	Stainless Steel	Stainless Steel	Edelstahl	Stainless Steel	Stainless Steel
<b>6</b>	PA66 30% GF	PA66 30% GF	PA66 30% GF	PA66 30% GF	PA66 30% GF
<b>7</b>	Silicon	Silicon	Silicon	Silicon	Silicon
<b>8</b>	Vinyl	Vinyl	Vinyl	Vinyl	Vinyl
<b>9</b>	Copper	Copper	Kupfer	Copper	Copper
<b>10</b>	Melamine	Melamine	Melaminschaum	Melamine	Melamine
<b>11</b>	Glass	Glass	Glas	Glass	Glass

LAST PAGE